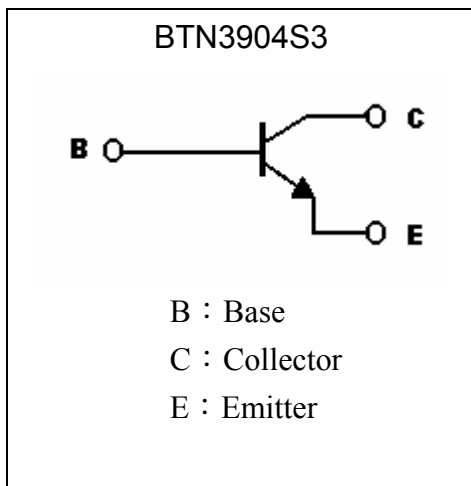
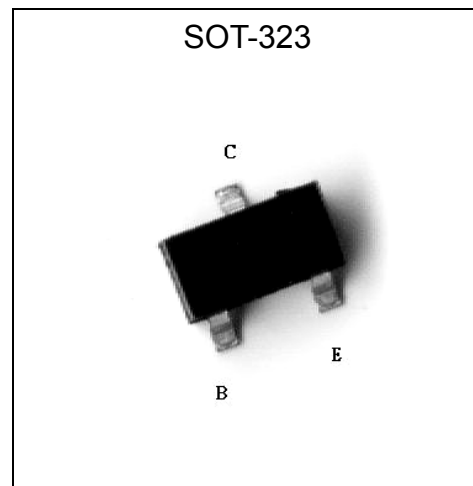

**General Purpose NPN Epitaxial Planar Transistor**

# BTN3904S3

**Description**

- The BTN3904S3 is designed for general purpose switching amplifier applications.
- Complementary to BTP3906S3.
- Pb-free package

**Symbol**

**Outline**

**Absolute Maximum Ratings** (Ta=25°C)

Parameter	Symbol	Limits	Unit
Collector-Base Voltage	V <sub>CB0</sub>	60	V
Collector-Emitter Voltage	V <sub>CEO</sub>	40	V
Emitter-Base Voltage	V <sub>EB0</sub>	6	V
Collector Current	I <sub>C</sub>	200	mA
Power Dissipation (T <sub>A</sub> =25°C)	P <sub>D</sub>	150 (Note)	mW
Thermal Resistance, Junction to Ambient	R <sub>θJA</sub>	833 (Note)	°C/W
Operating Junction and Storage Temperature Range	T <sub>j</sub> ; T <sub>sig</sub>	-55~+150	°C

Note : Device mounted on FR-4 glass epoxy printed circuit board using the minimum footprint.

**Characteristics (Ta=25°C)**

Symbol	Min.	Typ.	Max.	Unit	Test Conditions
BV <sub>CBO</sub>	60	-	-	V	I <sub>C</sub> =10μA
BV <sub>CEO</sub>	40	-	-	V	I <sub>C</sub> =1mA
BV <sub>EBO</sub>	6	-	-	V	I <sub>E</sub> =10μA
I <sub>CEX</sub>	-	-	50	nA	V <sub>CE</sub> =30V, V <sub>EB</sub> =3V
*V <sub>CE(sat)1</sub>	-	-	0.2	V	I <sub>C</sub> =10mA, I <sub>B</sub> =1mA
*V <sub>CE(sat)2</sub>	-	-	0.3	V	I <sub>C</sub> =50mA, I <sub>B</sub> =5mA
*V <sub>BE(sat)1</sub>	0.65	-	0.85	V	I <sub>C</sub> =10mA, I <sub>B</sub> =1mA
*V <sub>BE(sat)2</sub>	-	-	0.95	V	I <sub>C</sub> =50mA, I <sub>B</sub> =5mA
*h <sub>FE1</sub>	40	-	-		V <sub>CE</sub> =1V, I <sub>C</sub> =100μA
*h <sub>FE2</sub>	70	-	-		V <sub>CE</sub> =1V, I <sub>C</sub> =1mA
*h <sub>FE3</sub>	100	-	300		V <sub>CE</sub> =1V, I <sub>C</sub> =10mA
*h <sub>FE4</sub>	60	-	-		V <sub>CE</sub> =1V, I <sub>C</sub> =50mA
*h <sub>FE5</sub>	30	-	-		V <sub>CE</sub> =1V, I <sub>C</sub> =100mA
f <sub>T</sub>	300	-	-	MHz	V <sub>CE</sub> =20V, I <sub>C</sub> =10mA, f=100MHz
C <sub>ob</sub>	-	-	4	pF	V <sub>CB</sub> =5V, I <sub>E</sub> =0A, f=1MHz

\*Pulse Test: Pulse Width ≤300μs, Duty Cycle ≤2%

**Ordering Information**

Device	Package	Shipping
BTN3904S3	SOT-323 (Pb-free package)	3000 pcs / Tape & Reel

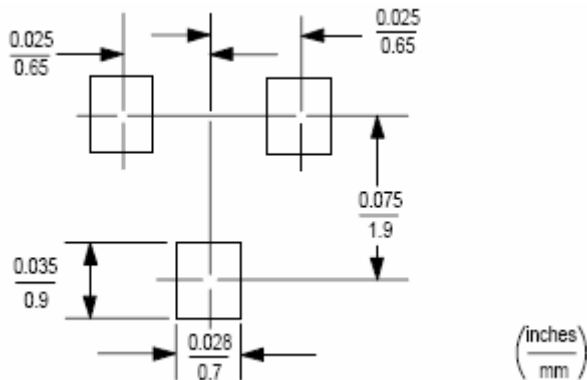
**Recommended Footprint**



### Typical Characteristics

Current Gain vs Collector Current

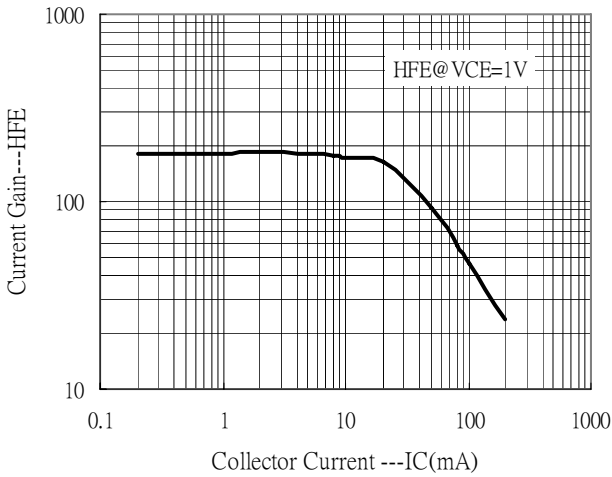

Saturation Voltage vs Collector Current

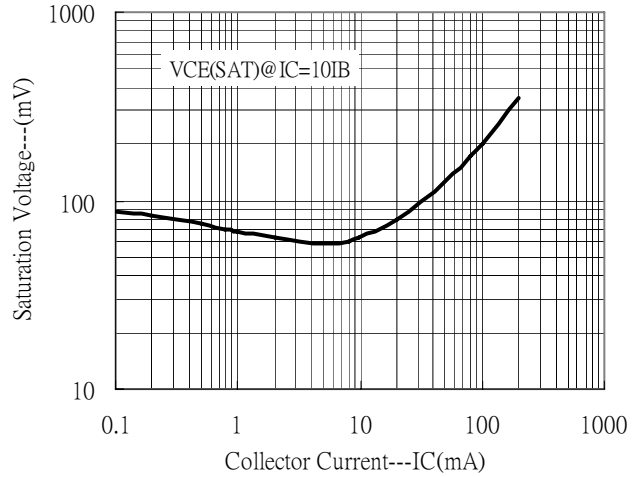

Saturation Voltage vs Collector Current

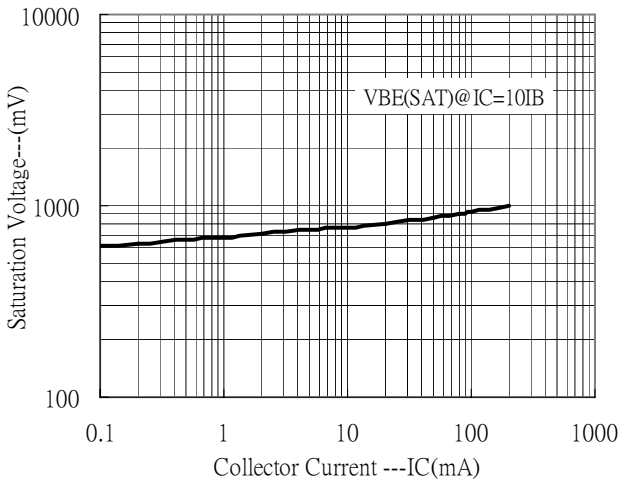

Cutoff Frequency vs Collector Current

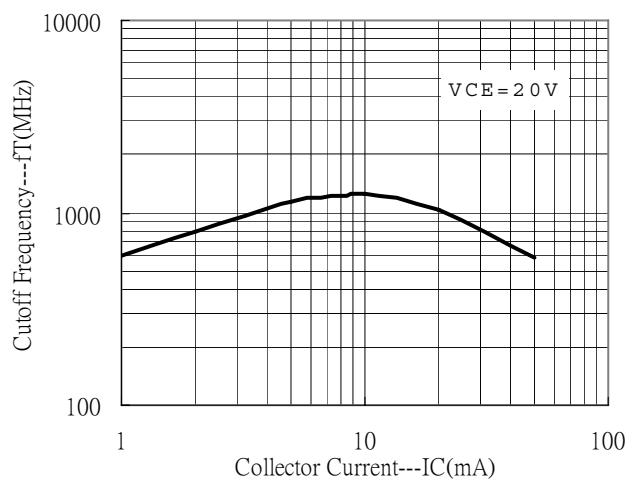

Power Derating Curve

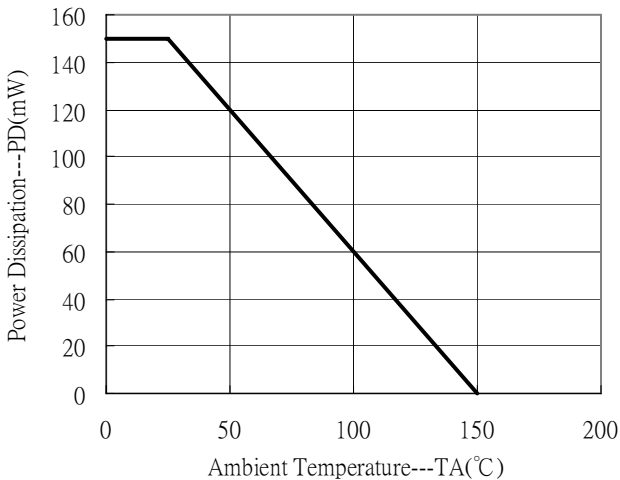

**Reel Dimension**

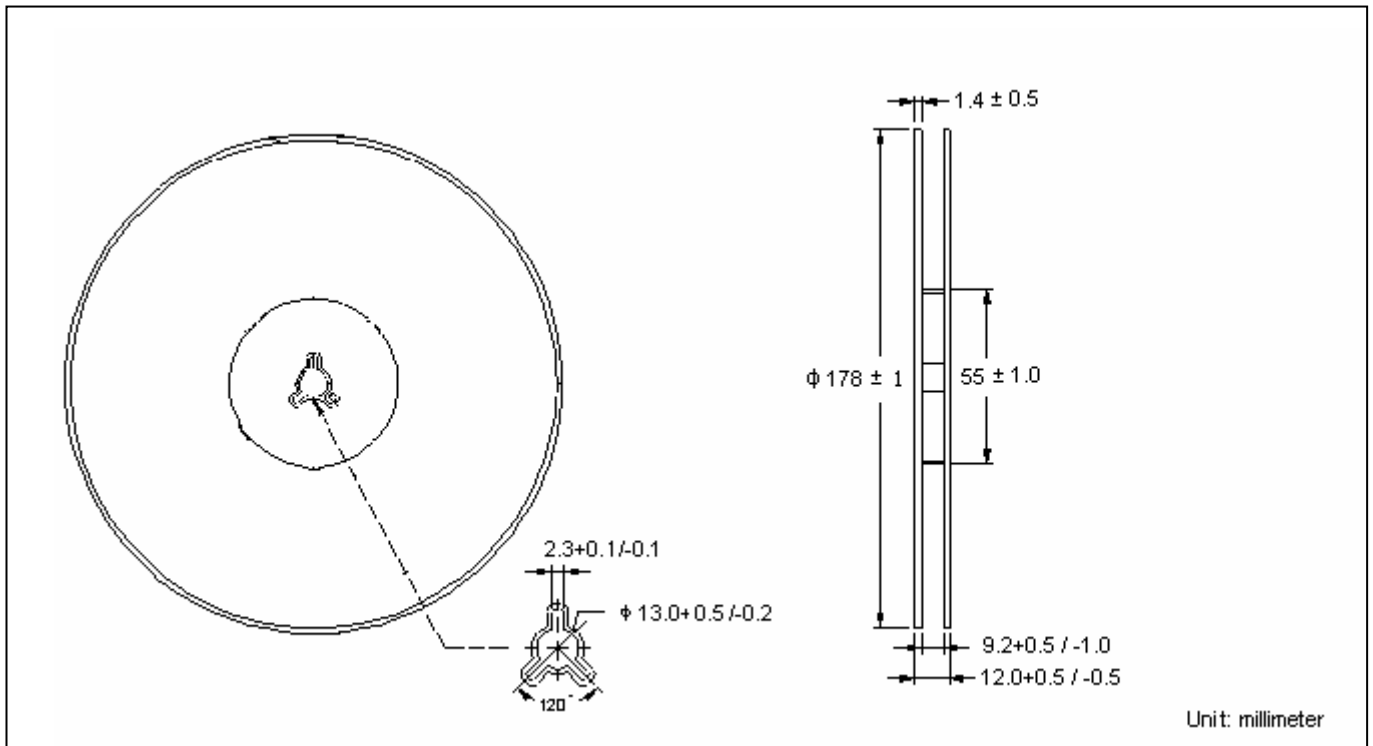

**Carrier Tape Dimension**

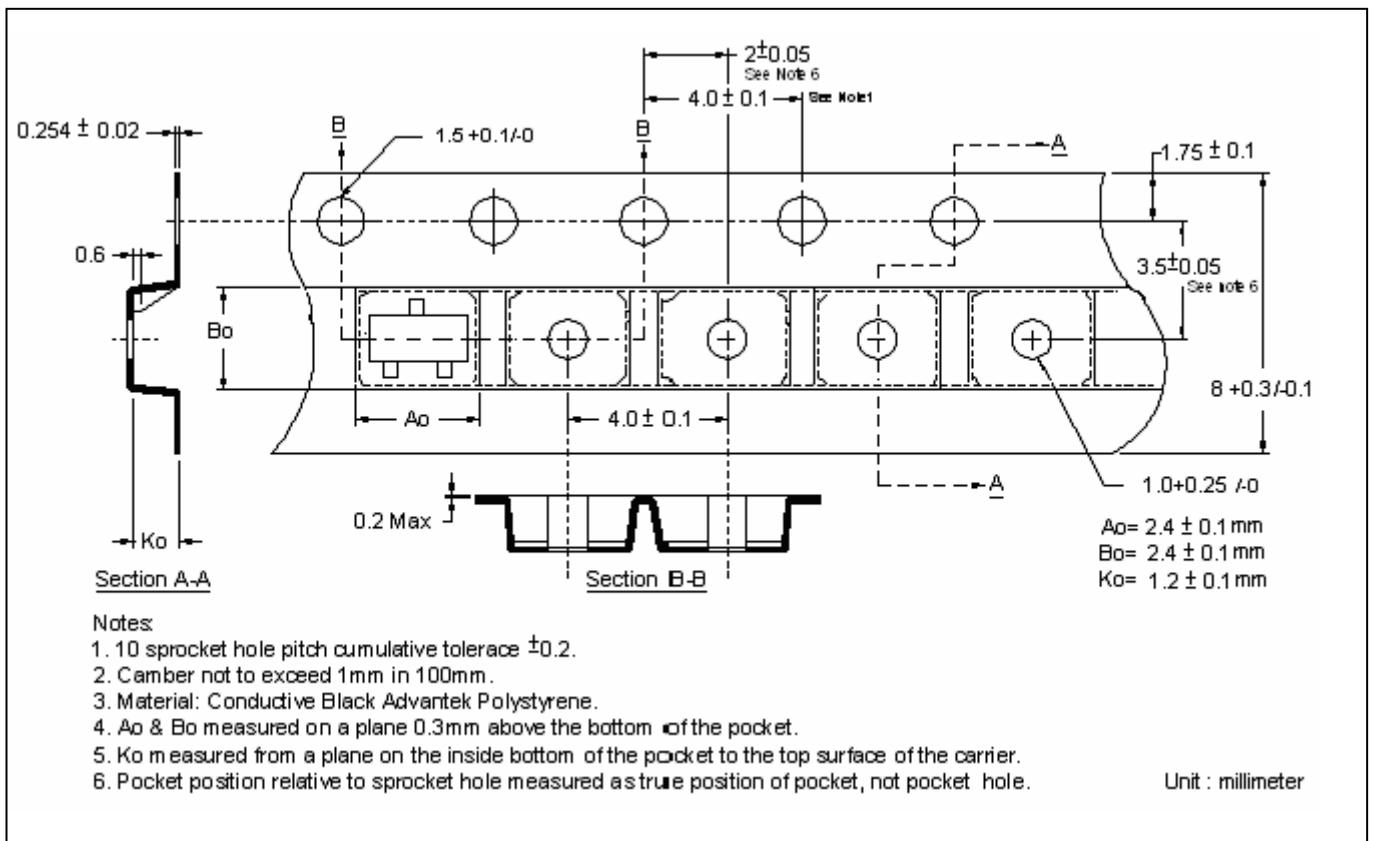

**Recommended wave soldering condition**

Product	Peak Temperature	Soldering Time
Pb-free devices	260 +0/-5 °C	5 +1/-1 seconds

**Recommended temperature profile for IR reflow**

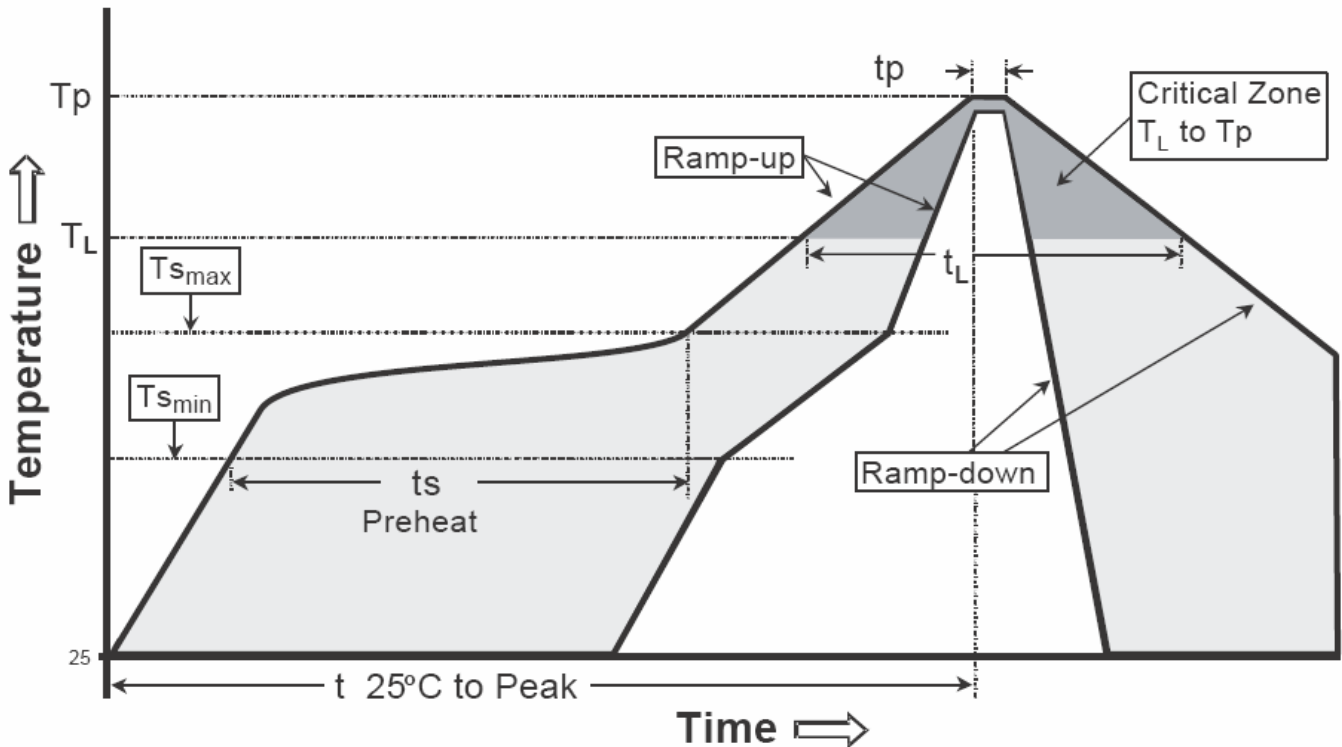

Profile feature	Sn-Pb eutectic Assembly	Pb-free Assembly
Average ramp-up rate (T <sub>smax</sub> to T <sub>p</sub> )	3°C/second max.	3°C/second max.
Preheat		
-Temperature Min(T <sub>s min</sub> )	100°C	150°C
-Temperature Max(T <sub>s max</sub> )	150°C	200°C
-Time(t <sub>s min</sub> to t <sub>s max</sub> )	60-120 seconds	60-180 seconds
Time maintained above:		
-Temperature (T <sub>L</sub> )	183°C	217°C
- Time (t <sub>L</sub> )	60-150 seconds	60-150 seconds
Peak Temperature(T <sub>P</sub> )	240 +0/-5 °C	260 +0/-5 °C
Time within 5°C of actual peak temperature(tp)	10-30 seconds	20-40 seconds
Ramp down rate	6°C/second max.	6°C/second max.
Time 25 °C to peak temperature	6 minutes max.	8 minutes max.

Note : All temperatures refer to topside of the package, measured on the package body surface.

**SOT-323 Dimension**

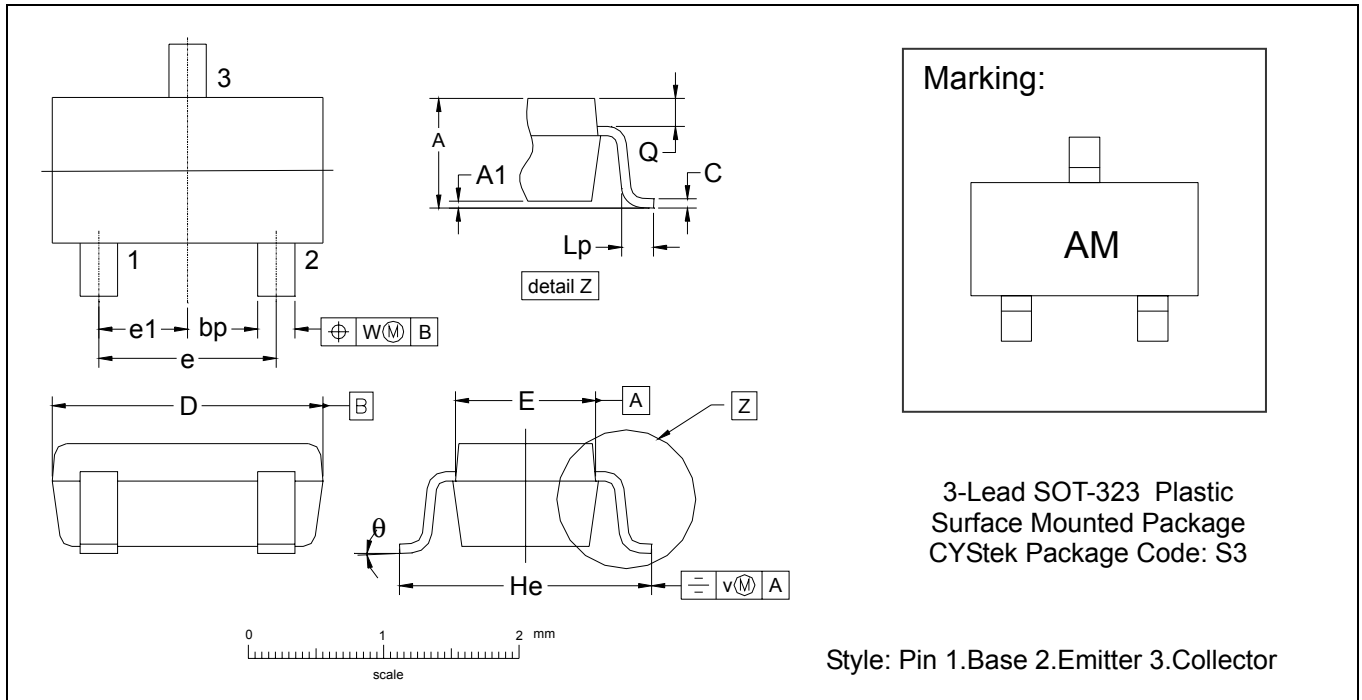

DIM	Inches		Millimeters		DIM	Inches		Millimeters	
	Min.	Max.	Min.	Max.		Min.	Max.	Min.	Max.
A	0.0315	0.0433	0.80	1.10	e1	0.0256	-	0.65	-
A1	0.0000	0.0039	0.00	0.10	He	0.0787	0.0886	2.00	2.25
bp	0.0118	0.0157	0.30	0.40	Lp	0.0059	0.0177	0.15	0.45
C	0.0039	0.0098	0.10	0.25	Q	0.0051	0.0091	0.13	0.23
D	0.0709	0.0866	1.80	2.20	v	0.0079	-	0.2	-
E	0.0453	0.0531	1.15	1.35	w	0.0079	-	0.2	-
e	0.0512	-	1.3	-	θ	-	-	10°	0°

**Notes:** 1.Controlling dimension: millimeters.  
 2.Maximum lead thickness includes lead finish thickness, and minimum lead thickness is the minimum thickness of base material.  
 3.If there is any question with packing specification or packing method, please contact your local CYStek sales office.

**Material:**

- Lead: Pure tin plated
- Mold Compound: Epoxy resin family, flammability solid burning class: UL94V-0

**Important Notice:**

- All rights are reserved. Reproduction in whole or in part is prohibited without the prior written approval of CYStek.
- CYStek reserves the right to make changes to its products without notice.
- CYStek **semiconductor products are not warranted to be suitable for use in Life-Support Applications, or systems.**
- CYStek assumes no liability for any consequence of customer product design, infringement of patents, or application assistance.