

# NPN Epitaxial Planar Transistor

## BTN1053M3

$BV_{CEO}$	75V
$I_C$	2.5A
$R_{CESAT(MAX)}$	250m $\Omega$

### Features

- 2W power dissipation
- Excellent  $H_{FE}$  Characteristics up to 1A
- Low Saturation Voltage,  $V_{CE(sat)}=0.15V(\text{typ})@I_C=1A, I_B=50mA$
- 5A peak pulse current
- Pb-free lead plating and halogen-free package

### Symbol

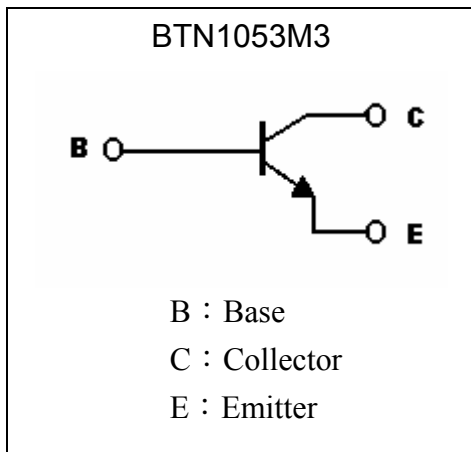

### Outline

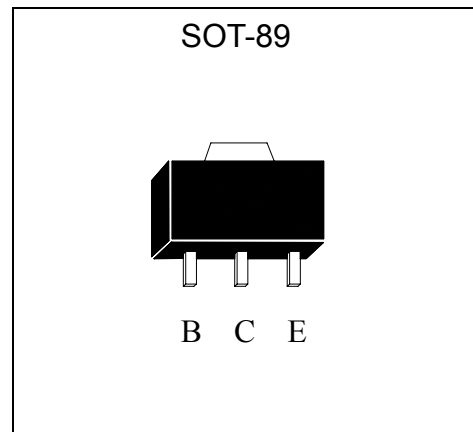

### Absolute Maximum Ratings (Ta=25°C)

Parameter	Symbol	Limits	Unit
Collector-Base Voltage	$V_{CBO}$	150	V
Collector-Emitter Voltage	$V_{CEO}$	75	V
Emitter-Base Voltage	$V_{EBO}$	5	V
Collector Current(DC)	$I_C$	2.5	A
Collector Current(Pulsed)(Note 1)	$I_{CP}$	5	
Power Dissipation @Ta=25°C	$P_D$	1 (Note 2)	W
		2 (Note 3)	
Operating Junction Temperature and Storage Range	$T_j ; T_{stg}$	-55~+150	°C

Note 1: Single pulse,  $P_w \leq 300\mu s$ , Duty Cycle  $\leq 2\%$ .

2: When the device is mounted on a FR-4 PCB measuring 15 x 15 x 0.6mm.

3: When the device is mounted on a ceramic substrate measuring 40 x 40 x 0.6mm.



Characteristics (Ta=25°C)

Symbol	Min.	Typ.	Max.	Unit	Test Conditions
BV <sub>CBO</sub>	150	250	-	V	I <sub>C</sub> =100μA
BV <sub>CES</sub>	150	250		V	I <sub>C</sub> =100μA
BV <sub>CEO</sub>	75	100	-	V	I <sub>C</sub> =10mA
BV <sub>EBO</sub>	5	7.7	-	V	I <sub>E</sub> =100μA
I <sub>CBO</sub>	-	0.9	10	nA	V <sub>CB</sub> =120V
I <sub>CES</sub>	-	0.9	10	nA	V <sub>CE</sub> =120V
I <sub>EBO</sub>	-	0.6	10	nA	V <sub>EB</sub> =4V
V <sub>CE(sat) 1</sub> *	-	-	40	mV	I <sub>C</sub> =200mA, I <sub>B</sub> =20mA
V <sub>CE(sat) 2</sub> *	-	-	200	mV	I <sub>C</sub> =500mA, I <sub>B</sub> =20mA
V <sub>CE(sat) 3</sub> *	-	-	400	mV	I <sub>C</sub> =1A, I <sub>B</sub> =10mA
V <sub>CE(sat) 4</sub> *	-	-	500	mV	I <sub>C</sub> =2A, I <sub>B</sub> =100mA
V <sub>BE(sat)</sub> *	-	0.9	1.2	V	I <sub>C</sub> =3A, I <sub>B</sub> =100mA
V <sub>BE(on)</sub> *	-	0.95	1.2	V	V <sub>CE</sub> =2V, I <sub>C</sub> =3A
h <sub>FE 1</sub> *	270	-	-	-	V <sub>CE</sub> =2V, I <sub>C</sub> =10mA
h <sub>FE 2</sub> *	300	600	820	-	V <sub>CE</sub> =2V, I <sub>C</sub> =500mA
h <sub>FE 3</sub> *	120	300	-	-	V <sub>CE</sub> =2V, I <sub>C</sub> =1A
h <sub>FE 4</sub> *	10	25	-	-	V <sub>CE</sub> =2V, I <sub>C</sub> =4.5A
f <sub>T</sub>	-	140	-	MHz	V <sub>CE</sub> =10V, I <sub>C</sub> =50mA, f=100MHz
Cob	-	23	-	pF	V <sub>CB</sub> =10V, I <sub>E</sub> =0A, f=1MHz

\*Pulse Test: Pulse Width ≤300μs, Duty Cycle≤2%

Classification Of h<sub>FE 2</sub>

Rank	S	T
Range	300~560	390~820

Ordering Information

Device	Package	Shipping	Marking
BTN1053M3	SOT-89 (Pb-free lead plating and halogen-free package)	1000 pcs / Tape & Reel	CB

Recommended Storage Condition:

Temperature : 10~ 35 °C  
Humidity : 30~ 60% RH

**Typical Characteristics**

Emitter Grounded Output Characteristics

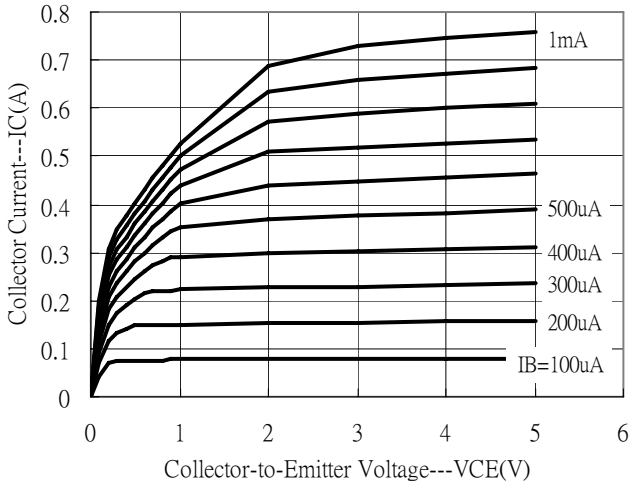

Emitter Grounded Output Characteristics

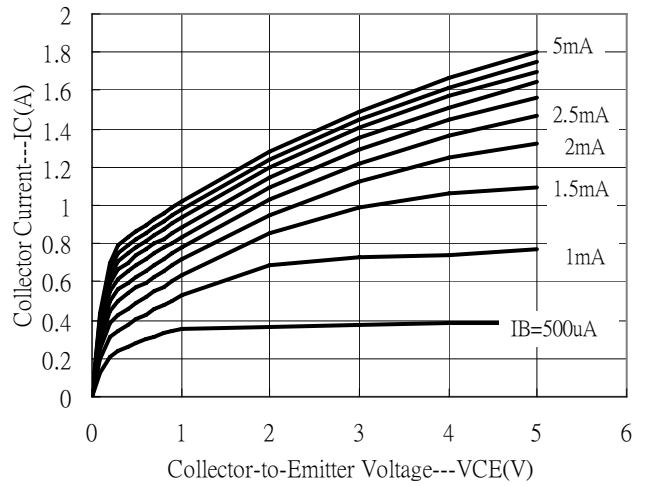

Emitter Grounded Output Characteristics

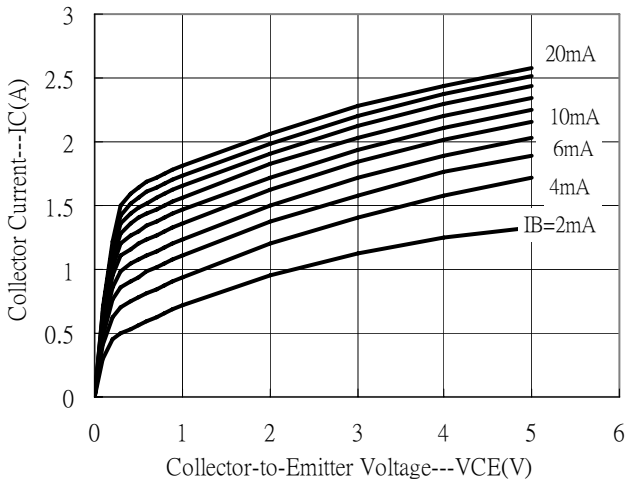

Emitter Grounded Output Characteristics

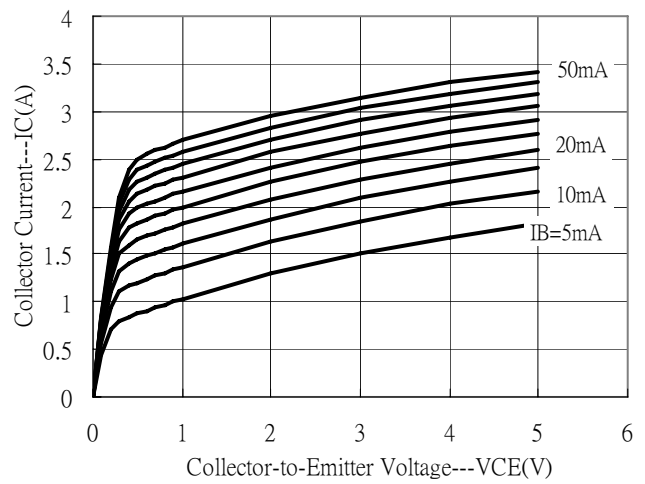

Current Gain vs Collector Current

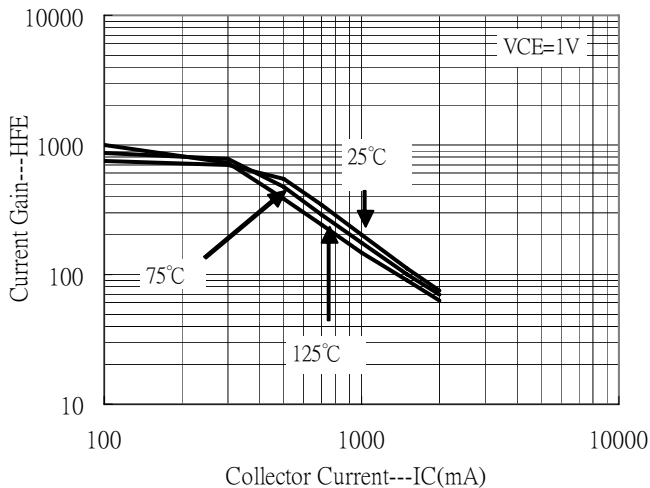

Current Gain vs Collector Current

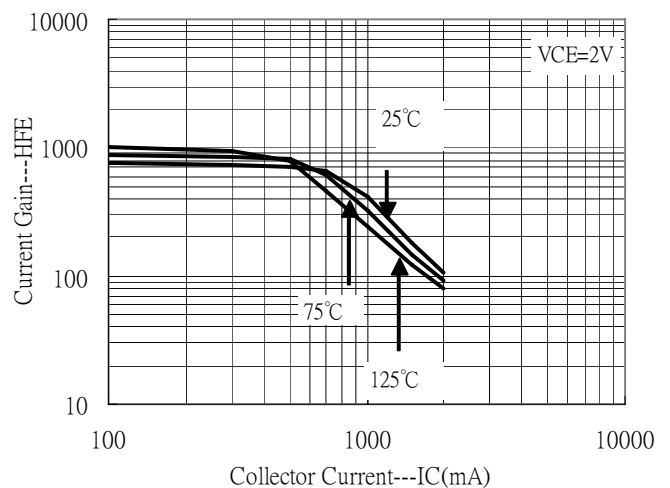

**Typical Characteristics(Cont.)**

Current Gain vs Collector Current

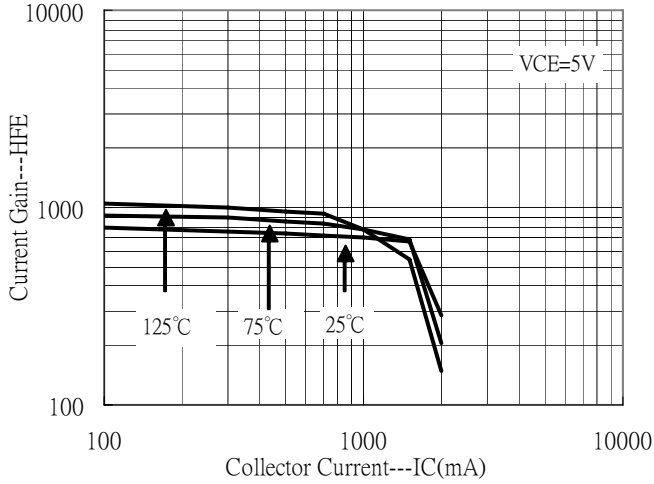

Saturation Voltage vs Collector Current

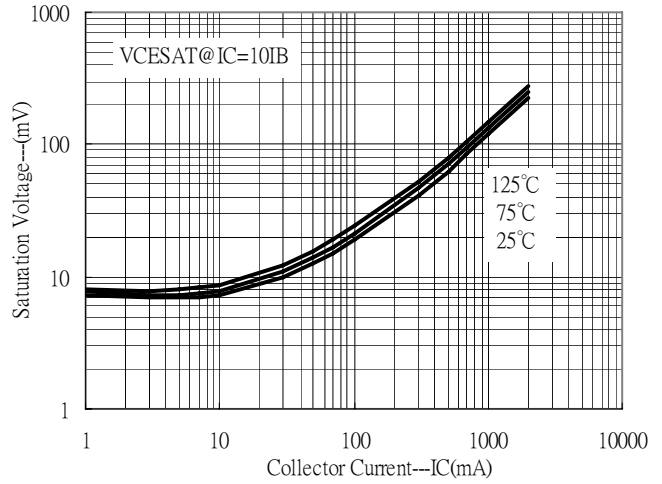

Saturation Voltage vs Collector Current

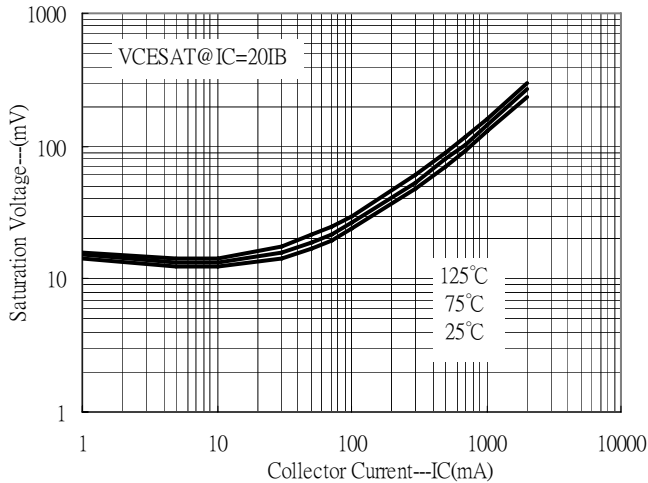

Saturation Voltage vs Collector Current

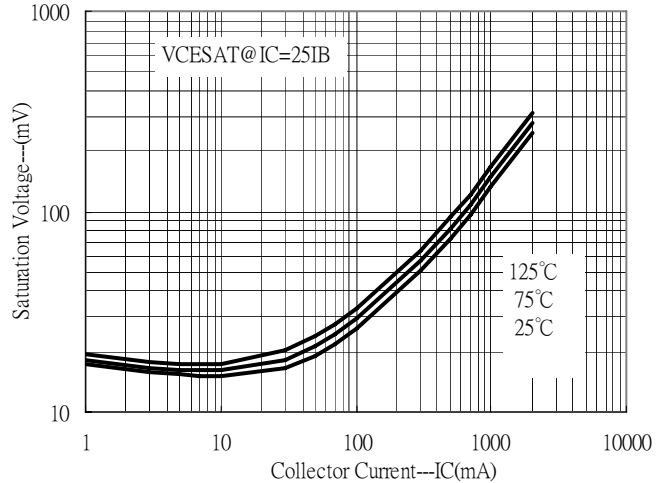

Saturation Voltage vs Collector Current

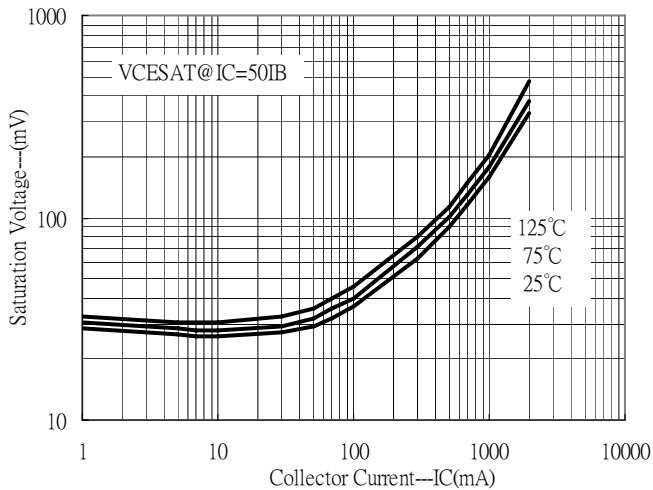

Saturation Voltage vs Collector Current

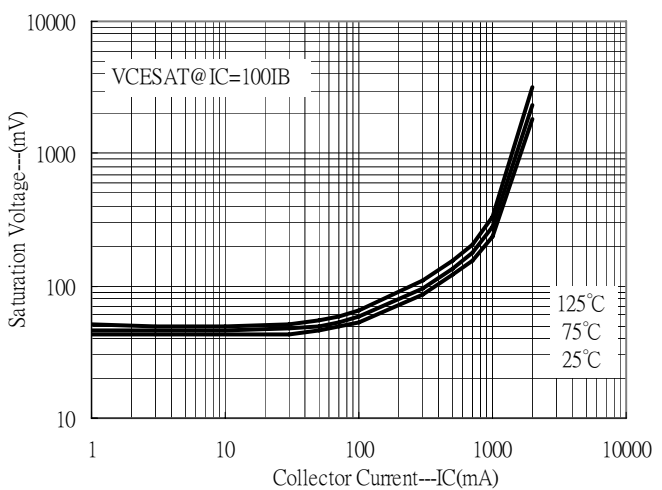

**Typical Characteristics(Cont.)**

On Voltage vs Collector Current

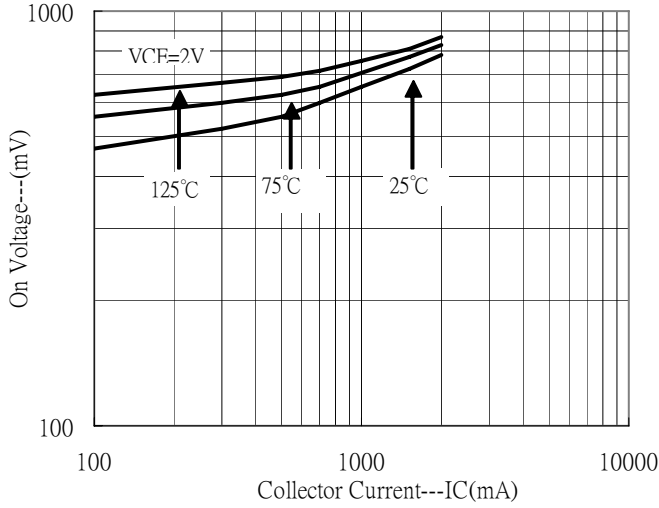

Capacitance vs Reverse-biased Voltage

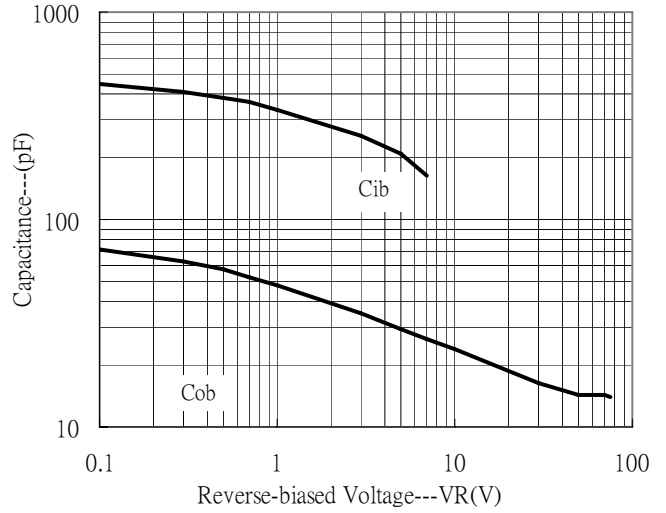

Power Derating Curve

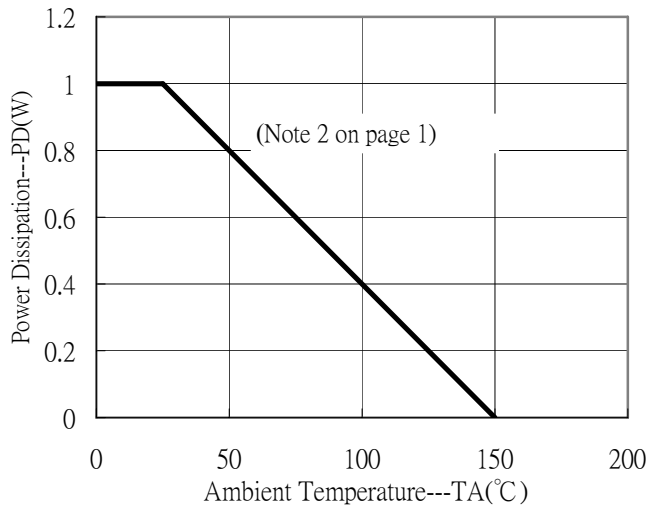

**Reel Dimension**

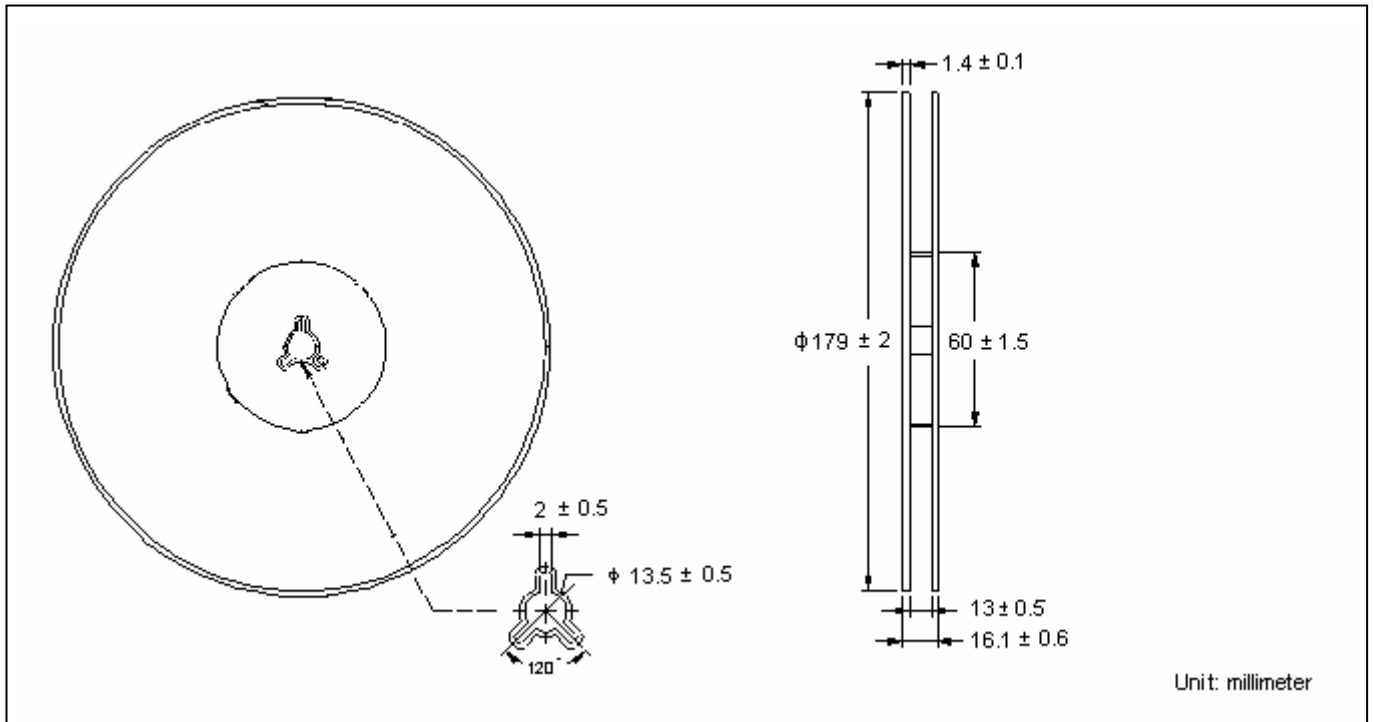

**Carrier Tape Dimension**

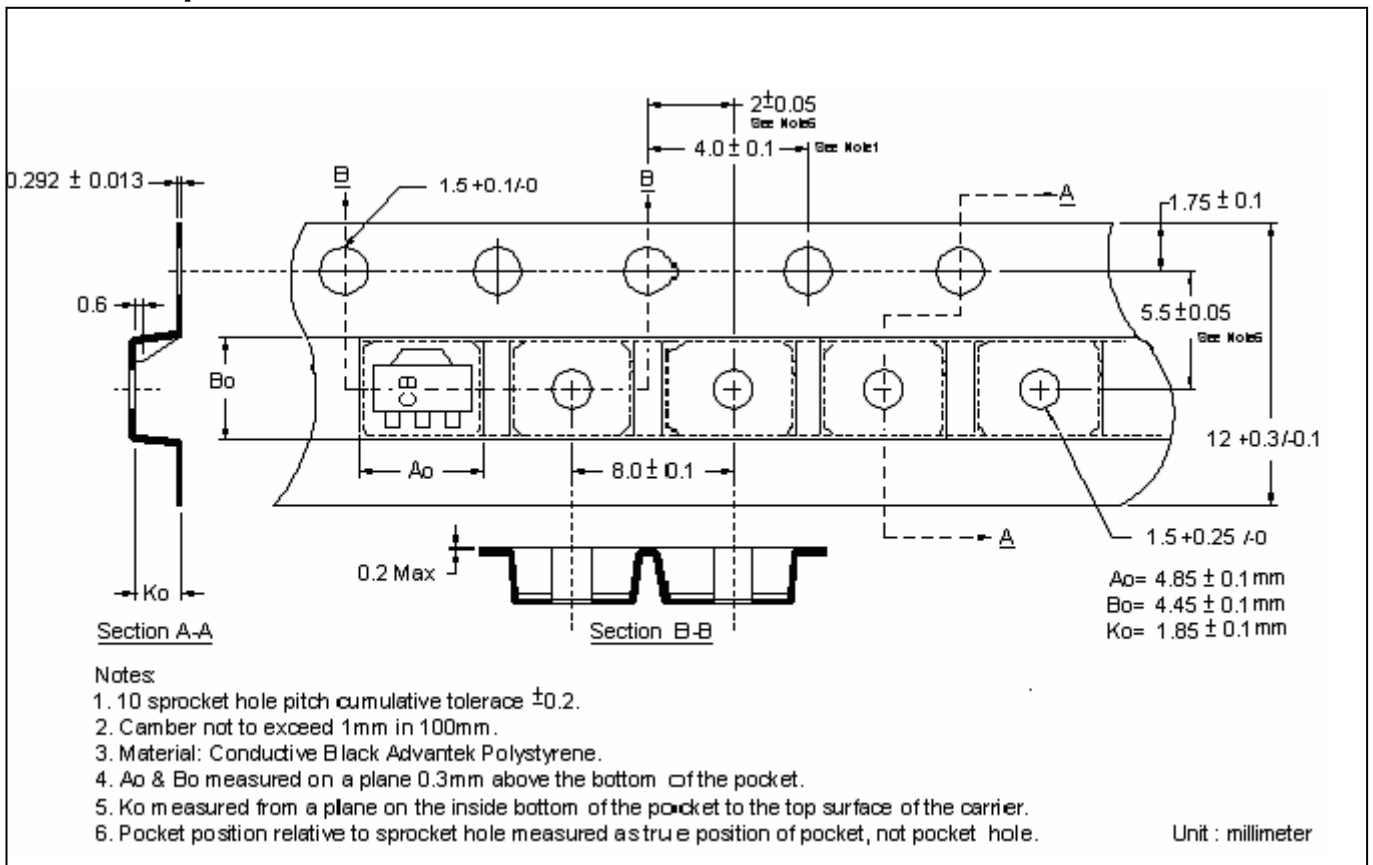

**Recommended wave soldering condition**

Product	Peak Temperature	Soldering Time
Pb-free devices	260 +0/-5 °C	5 +1/-1 seconds

**Recommended temperature profile for IR reflow**

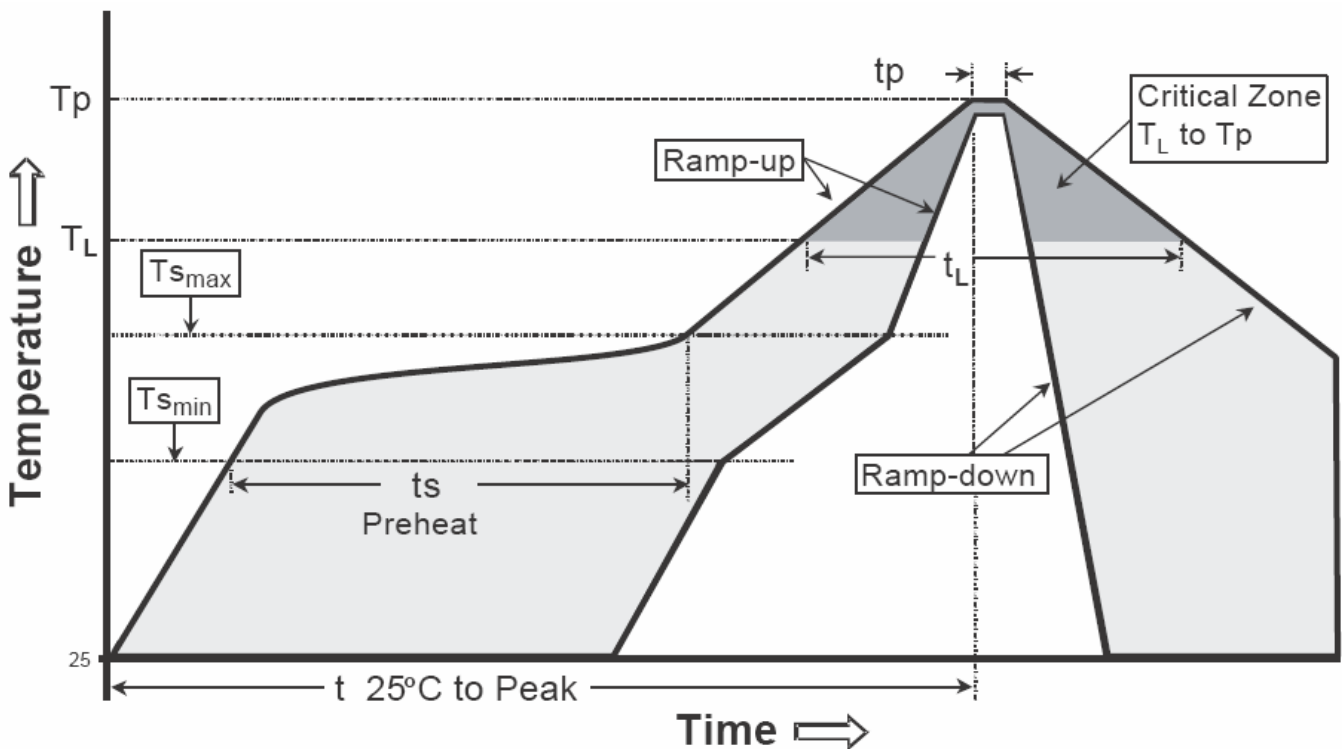

Profile feature	Sn-Pb eutectic Assembly	Pb-free Assembly
Average ramp-up rate (T <sub>smax</sub> to T <sub>p</sub> )	3°C/second max.	3°C/second max.
Preheat		
-Temperature Min(T <sub>s min</sub> )	100°C	150°C
-Temperature Max(T <sub>s max</sub> )	150°C	200°C
-Time(t <sub>s min</sub> to t <sub>s max</sub> )	60-120 seconds	60-180 seconds
Time maintained above:		
-Temperature (T <sub>L</sub> )	183°C	217°C
- Time (t <sub>L</sub> )	60-150 seconds	60-150 seconds
Peak Temperature(T <sub>P</sub> )	240 +0/-5 °C	260 +0/-5 °C
Time within 5°C of actual peak temperature(tp)	10-30 seconds	20-40 seconds
Ramp down rate	6°C/second max.	6°C/second max.
Time 25 °C to peak temperature	6 minutes max.	8 minutes max.

Note : All temperatures refer to topside of the package, measured on the package body surface.

**SOT-89 Dimension**

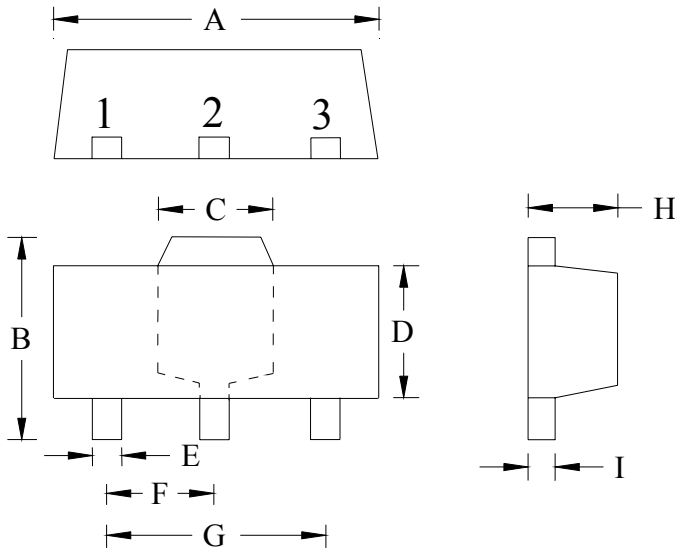

The diagram shows three views of the SOT-89 package: a top view with dimensions A, C, E, F, and G; a front view with dimensions B, D, and I; and a side view with dimension H. The top view also labels pins 1, 2, and 3.

**Marking:**

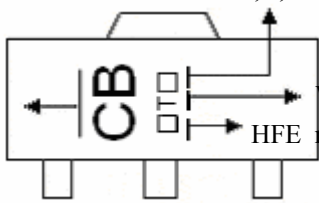

month code: 1~9, A,B,C  
 Product Code  
 Wafer code  
 HFE rank

Style: Pin 1. Base 2. Collector 3. Emitter

3-Lead SOT-89 Plastic  
 Surface Mounted Package  
 CYStek Package Code: M3

DIM	Inches		Millimeters		DIM	Inches		Millimeters	
	Min.	Max.	Min.	Max.		Min.	Max.	Min.	Max.
A	0.1732	0.1811	4.40	4.60	F	0.0591	TYP	1.50	TYP
B	0.1551	0.1673	3.94	4.25	G	0.1181	TYP	3.00	TYP
C	0.0610	REF	1.55	REF	H	0.0551	0.0630	1.40	1.60
D	0.0906	0.1024	2.30	2.60	I	0.0138	0.0173	0.35	0.44
E	0.0126	0.0205	0.32	0.52					

- Notes:**
- Controlling dimension: millimeters.
  - Maximum lead thickness includes lead finish thickness, and minimum lead thickness is the minimum thickness of base material.
  - If there is any question with packing specification or packing method, please contact your local CYStek sales office.

**Material:**

- Lead: KFC ;pure tin plated.
- Mold Compound: Epoxy resin family, flammability solid burning class: UL94V-0.

**Important Notice:**

- All rights are reserved. Reproduction in whole or in part is prohibited without the prior written approval of CYStek.
- CYStek reserves the right to make changes to its products without notice.
- CYStek **semiconductor products are not warranted to be suitable for use in Life-Support Applications, or systems.**
- CYStek assumes no liability for any consequence of customer product design, infringement of patents, or application assistance.