

Low Vcesat PNP Epitaxial Planar Transistor

D45H11E3

Features

- Low VCE(sat)
- High BVCEO
- Excellent current gain characteristics
- Pb-free lead plating package

Symbol

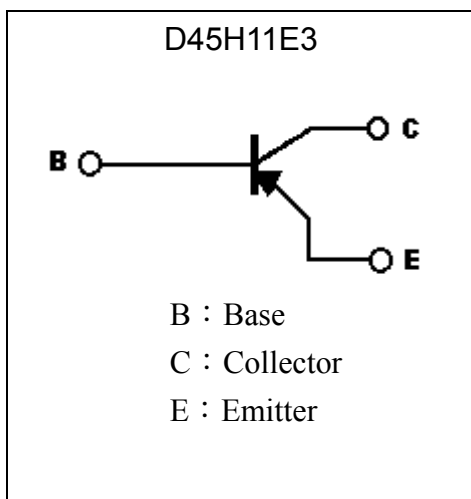

Outline

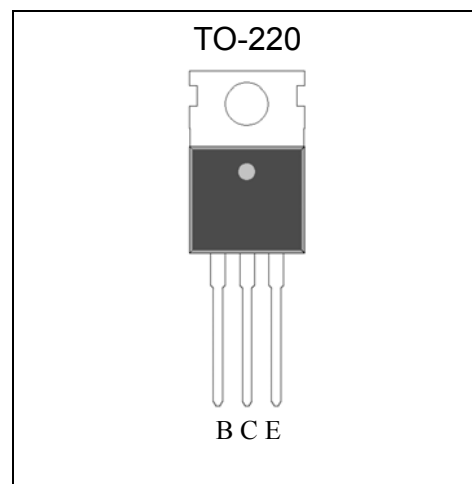

Ordering Information

Device	Package	Shipping
D45H11E3-0-UB-S	TO-220 (Pb-free lead plating)	50 pcs / tube, 20 tubes/ box , 4 boxes/carton

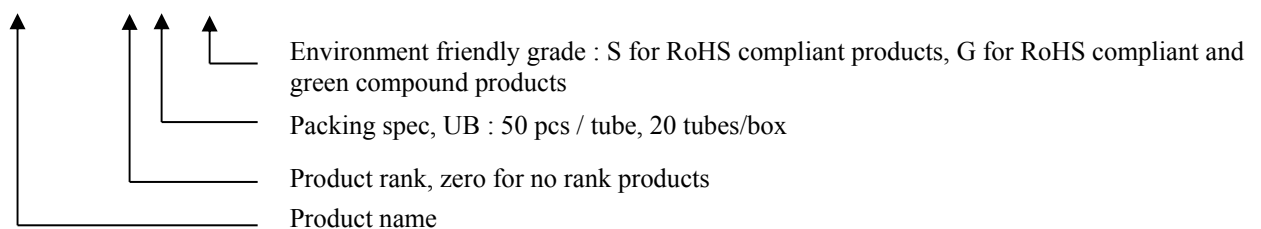



Absolute Maximum Ratings (Ta=25°C)

Parameter	Symbol	Limits	Unit
Collector-Base Voltage	V _{CB0}	-80	V
Collector-Emitter Voltage	V _{CE0}	-80	V
Emitter-Base Voltage	V _{EBO}	-5	V
Collector Current (DC)	I _C	-10	A
Collector Current (Pulse)	I _{CP}	-20 (Note 1)	
Power Dissipation @ T _A =25°C	P _D	2	W
Power Dissipation @ T _C =25°C	P _D	50	
Thermal Resistance, Junction to Ambient	R _{θJA}	62.5	°C/W
Thermal Resistance, Junction to Case	R _{θJC}	2.5	°C/W
Junction Temperature	T _J	150	°C
Storage Temperature	T _{stg}	-55~+150	°C

Note : 1. Single Pulse , P_w ≤ 380μs, Duty ≤ 2%.

Characteristics (Ta=25°C)

Symbol	Min.	Typ.	Max.	Unit	Test Conditions
BV _{CEO(SUS)}	-80	-	-	V	I _C =-30mA, I _B =0
I _{CEO}	-	-	-10	μA	V _{CE} =-80V, I _B =0
I _{CES}	-	-	-10	μA	V _{CE} =-80V, V _{BE} =0
I _{EBO}	-	-	-50	μA	V _{EB} =-5V, I _C =0
*V _{CE(sat)}	-	-0.6	-1.0	V	I _C =-8A, I _B =-0.4A
*V _{BE(sat)}	-	-1.0	-1.5	V	I _C =-8A, I _B =-0.8A
*h _{FE}	60	-	-	-	V _{CE} =-1V, I _C =-2A
*h _{FE}	40	-	-	-	V _{CE} =-1V, I _C =-4A
f _T	-	40	-	MHz	V _{CE} =-10V, I _C =-500mA, f=20MHz
C _{ob}	-	230	-	pF	V _{CB} =-10V, f=1MHz

*Pulse Test : Pulse Width ≤ 380μs, Duty Cycle ≤ 2%

Typical Characteristics

Current Gain vs Collector Current

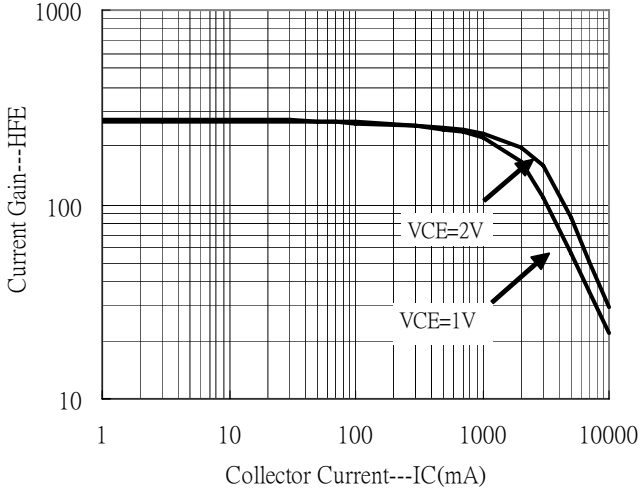

Saturation Voltage vs Collector Current

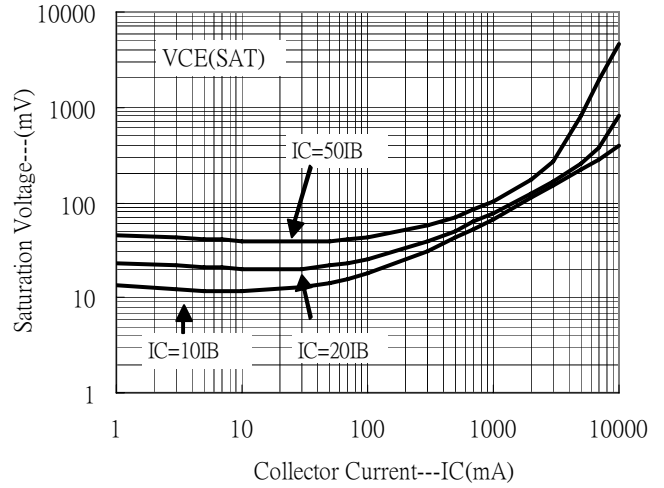

Saturation Voltage vs Collector Current

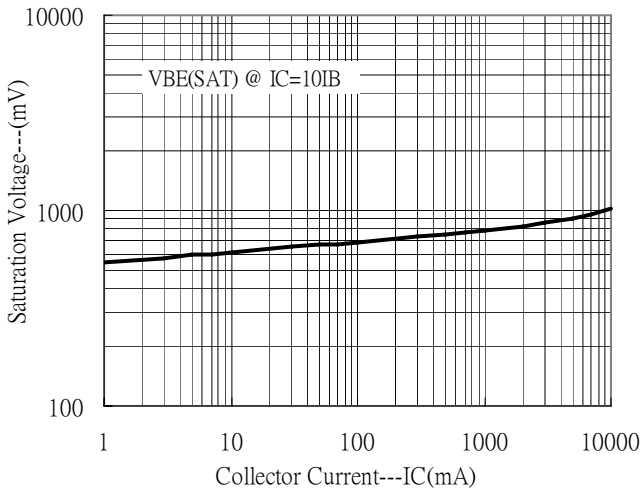

On Voltage vs Collector Current

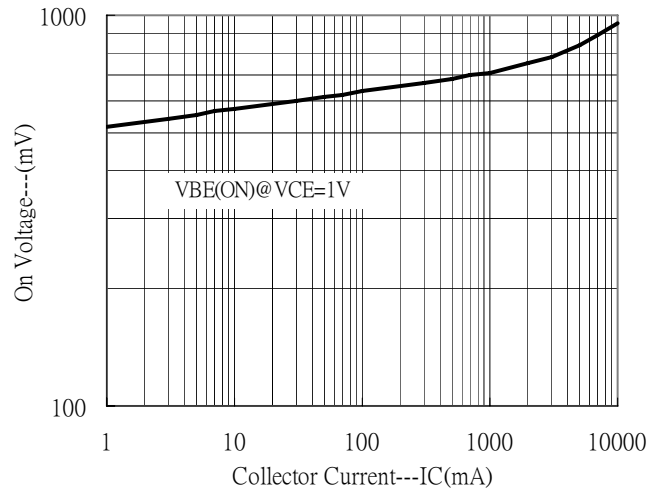

Power Derating Curve

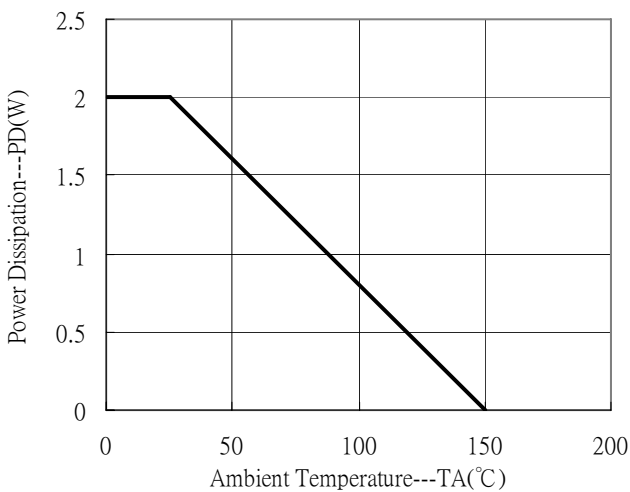

Power Derating Curve

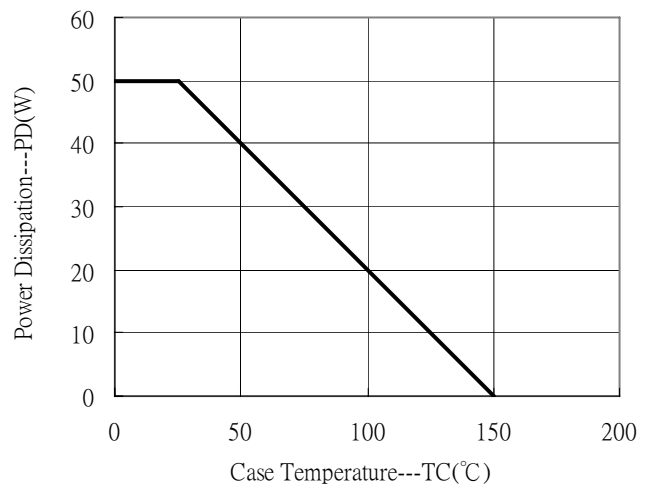

Recommended wave soldering condition

Product	Peak Temperature	Soldering Time
Pb-free devices	260 +0/-5 °C	5 +1/-1 seconds

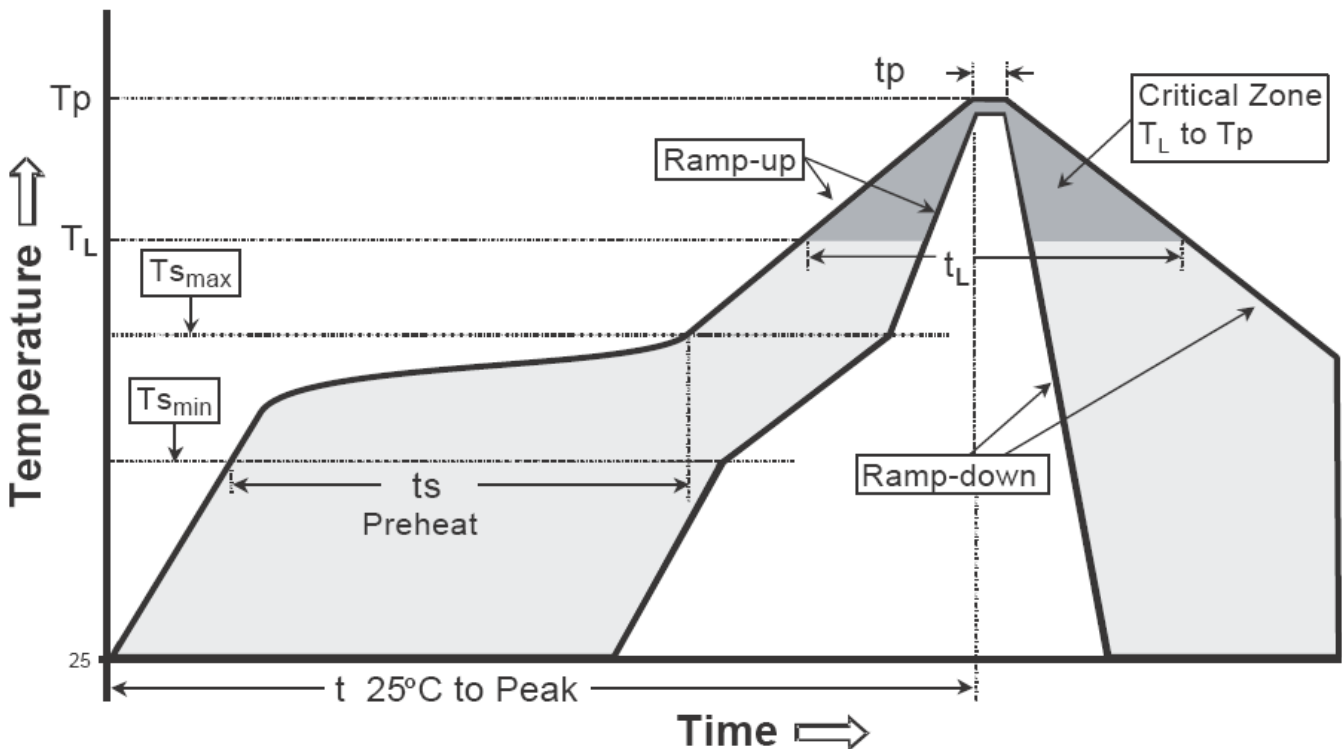
Recommended temperature profile for IR reflow

Profile feature	Sn-Pb eutectic Assembly	Pb-free Assembly
Average ramp-up rate (T _{smax} to T _p)	3°C/second max.	3°C/second max.
Preheat		
-Temperature Min(T _{s min})	100°C	150°C
-Temperature Max(T _{s max})	150°C	200°C
-Time(t _{s min} to t _{s max})	60-120 seconds	60-180 seconds
Time maintained above:		
-Temperature (T _L)	183°C	217°C
- Time (t _L)	60-150 seconds	60-150 seconds
Peak Temperature(T _P)	240 +0/-5 °C	260 +0/-5 °C
Time within 5°C of actual peak temperature(tp)	10-30 seconds	20-40 seconds
Ramp down rate	6°C/second max.	6°C/second max.
Time 25 °C to peak temperature	6 minutes max.	8 minutes max.

Note : All temperatures refer to topside of the package, measured on the package body surface.

TO-220 Dimension

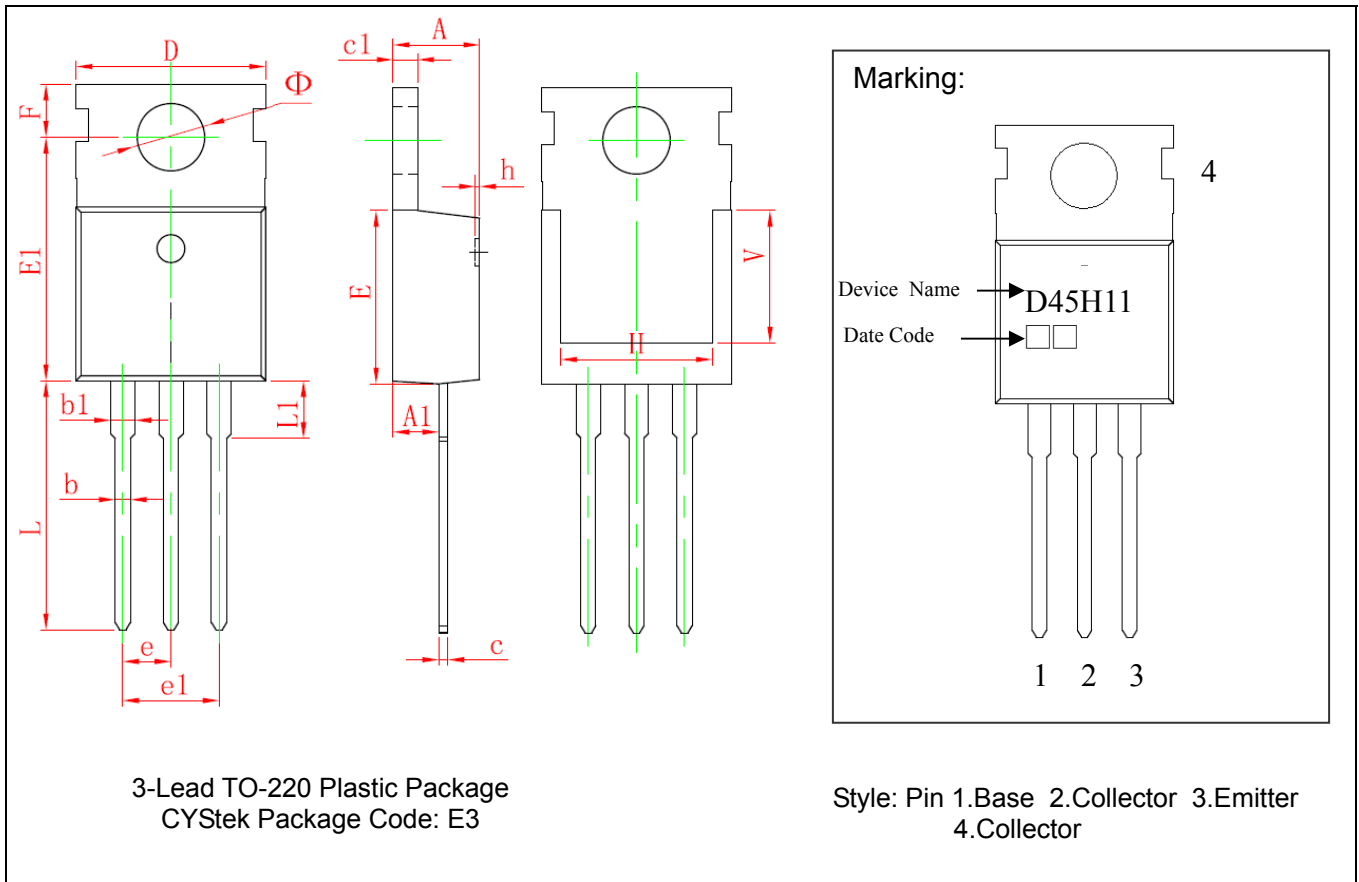

*: Typical

DIM	Millimeters		Inches		DIM	Millimeters		Inches	
	Min.	Max.	Min.	Max.		Min.	Max.	Min.	Max.
A	4.400	4.600	0.173	0.181	e	2.540*		0.100*	
A1	2.250	2.550	0.089	0.100	e1	4.980	5.180	0.196	0.204
b	0.710	0.910	0.028	0.036	F	2.650	2.950	0.104	0.116
b1	1.170	1.370	0.046	0.054	H	7.900	8.100	0.311	0.319
c	0.330	0.650	0.013	0.026	h	0.000	0.300	0.000	0.012
c1	1.200	1.400	0.047	0.055	L	12.900	13.400	0.508	0.528
D	9.910	10.250	0.390	0.404	L1	2.850	3.250	0.112	0.128
E	8.950	9.750	0.352	0.384	V	7/500	REF	0.295	REF
E1	12.650	12.950	0.498	0.510	Φ	3.400	3.800	0.134	0.150

Notes: 1.Controlling dimension: millimeters.
 2.Maximum lead thickness includes lead finish thickness, and minimum lead thickness is the minimum thickness of base material.
 3.If there is any question with packing specification or packing method, please contact your local CYStek sales office.

Material:

- Lead: Pure tin plated.
- Mold Compound: Epoxy resin family, flammability solid burning class: UL94V-0.

Important Notice:

- All rights are reserved. Reproduction in whole or in part is prohibited without the prior written approval of CYStek.
- CYStek reserves the right to make changes to its products without notice.
- CYStek **semiconductor products are not warranted to be suitable for use in Life-Support Applications, or systems.**
- CYStek assumes no liability for any consequence of customer product design, infringement of patents, or application assistance.