

Low Vcesat NPN Epitaxial Planar Transistor

D44H11J3

| | |
|-------------|--------------|
| BV_{CEO} | 80V |
| I_C | 8A |
| R_{CESAT} | 60m Ω |

Features

- Low $V_{CE(sat)}$
- High BV_{CEO}
- Excellent current gain characteristics
- RoHS compliant package

Symbol

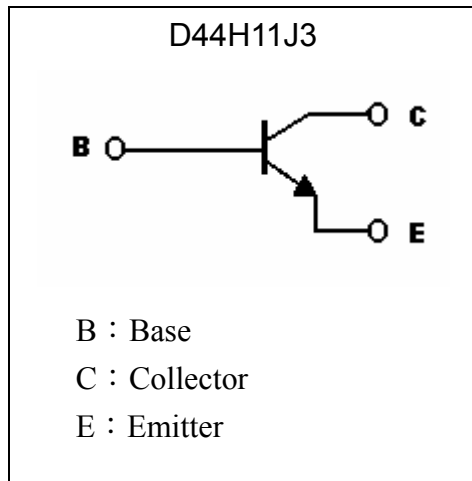

Outline

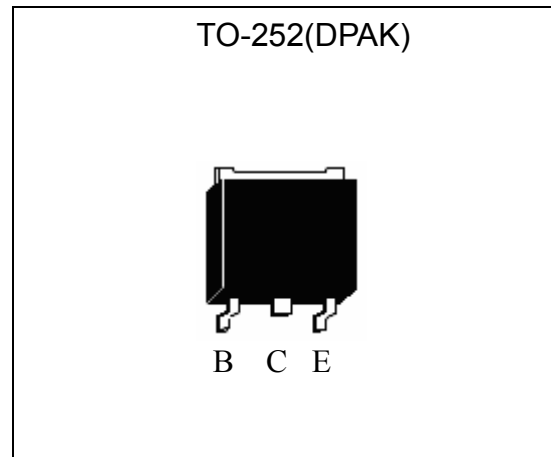

Absolute Maximum Ratings (Ta=25°C)

| Parameter | Symbol | Limits | Unit |
|--|-----------------|---------------|--------------------|
| Collector-Base Voltage | V_{CBO} | 80 | V |
| Collector-Emitter Voltage | V_{CEO} | 80 | V |
| Emitter-Base Voltage | V_{EBO} | 6 | V |
| Collector Current (DC) | I_C | 8 | A |
| Collector Current (Pulse) | I_{CP} | 16 (Note 1) | |
| Power Dissipation @ $T_A=25^\circ\text{C}$ | P_D | 1.75 (Note 2) | W |
| Power Dissipation @ $T_c=25^\circ\text{C}$ | P_D | 20 | |
| Thermal Resistance, Junction to Ambient | $R_{\theta JA}$ | 71.4 (Note 2) | $^\circ\text{C/W}$ |
| Thermal Resistance, Junction to Case | $R_{\theta JC}$ | 6.25 | $^\circ\text{C/W}$ |
| Junction Temperature | T_j | 150 | $^\circ\text{C}$ |
| Storage Temperature | T_{stg} | -55~+150 | $^\circ\text{C}$ |

Note : 1. Single Pulse , $P_w \leq 380\mu\text{s}$, $Duty \leq 2\%$.
 2. When mounted on a PCB with the minimum pad size.

**Characteristics (Ta=25°C)**

| Symbol | Min. | Typ. | Max. | Unit | Test Conditions |
|-----------------|------|------|------|---------|---------------------------------|
| $BV_{CEO(SUS)}$ | 80 | - | - | V | $I_C=30mA, I_B=0$ |
| I_{CES} | - | - | 10 | μA | $V_{CE}=80V, V_{BE}=0$ |
| I_{EBO} | - | - | 50 | μA | $V_{EB}=5V, I_C=0$ |
| $*V_{CE(sat)}$ | - | 0.3 | 0.6 | V | $I_C=8A, I_B=0.4A$ |
| $*V_{BE(sat)}$ | - | 1.0 | 1.5 | V | $I_C=8A, I_B=0.8A$ |
| $*h_{FE}$ | 60 | - | - | - | $V_{CE}=1V, I_C=2A$ |
| $*h_{FE}$ | 40 | - | - | - | $V_{CE}=1V, I_C=4A$ |
| f_T | - | 50 | - | MHz | $V_{CE}=6V, I_C=500mA, f=20MHz$ |
| Cob | - | 130 | - | pF | $V_{CB}=10V, f=1MHz$ |

*Pulse Test : Pulse Width $\leq 380\mu s$, Duty Cycle $\leq 2\%$ **Ordering Information**

| Device | Package | Shipping |
|-----------------|---|------------------------|
| D44H11J3-0-T3-G | TO-252 (Pb-free lead plating and halogen-free package) | 2500 pcs / Tape & Reel |

Typical Characteristics

Grounded Emitter Output Characteristics

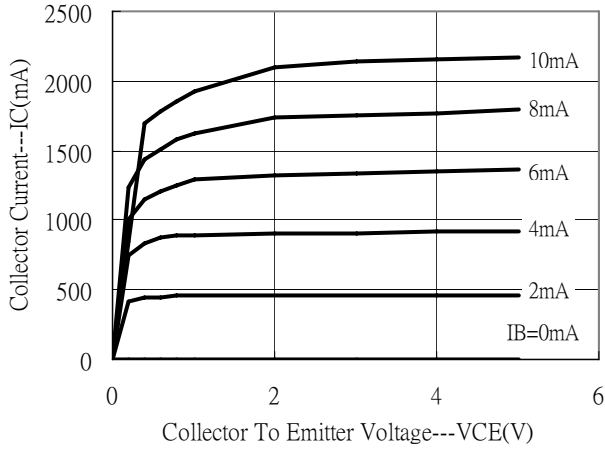

Grounded Emitter Output Characteristics

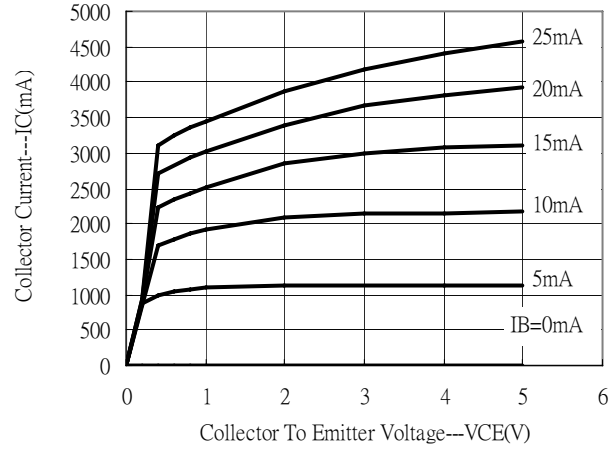

Grounded Emitter Output Characteristics

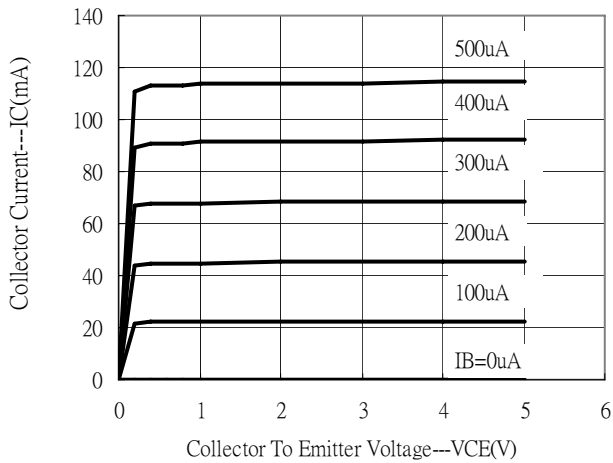

Grounded Emitter Output Characteristics

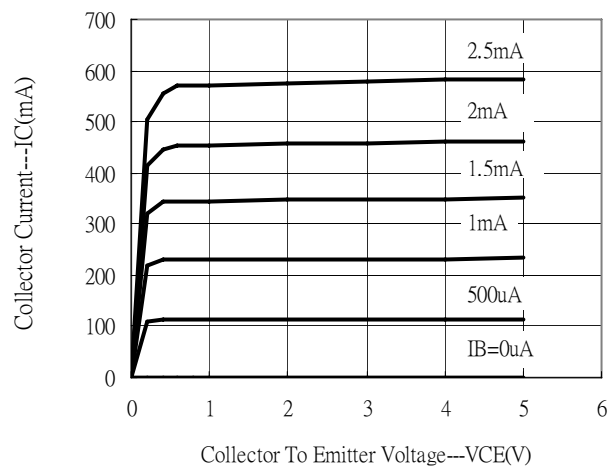

Current Gain vs Collector Current

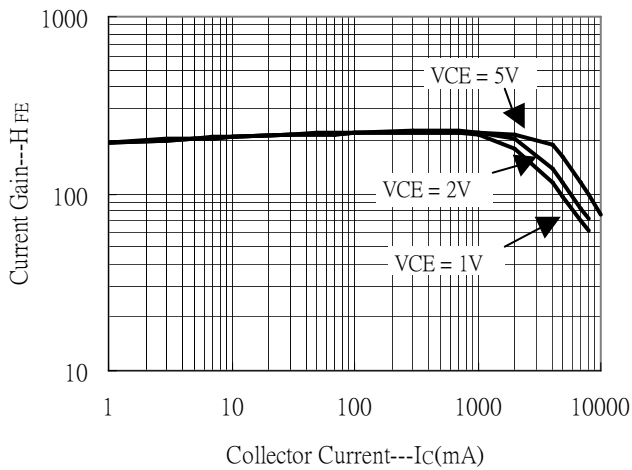

Saturation Voltage vs Collector Current

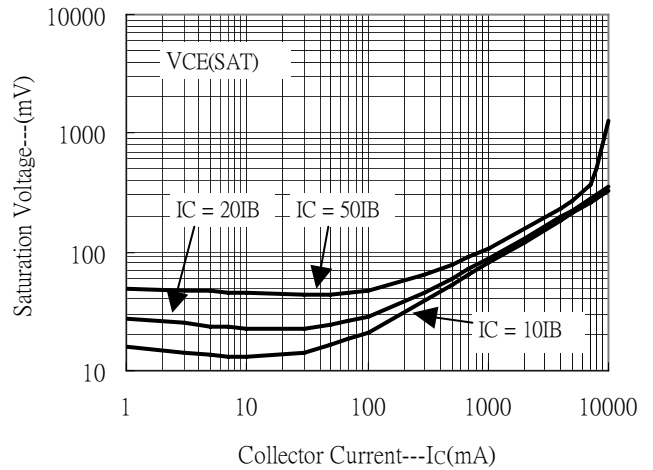



Characteristic Curves(Cont.)

Saturation Voltage vs Collector Current

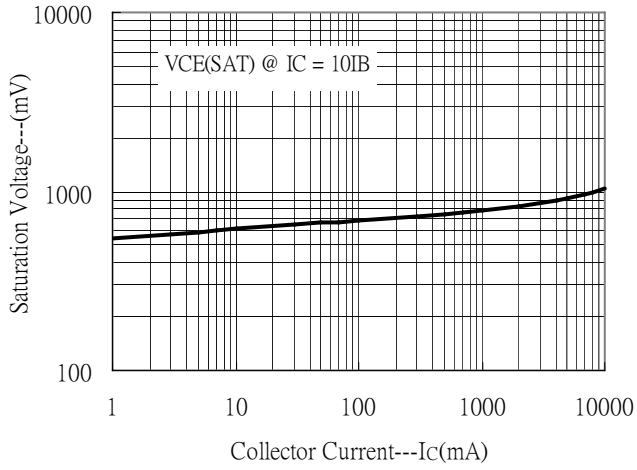

Power Derating Curve

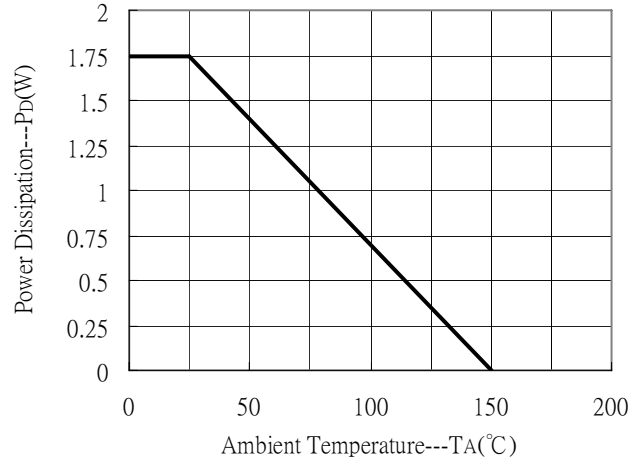

Power Derating Curve

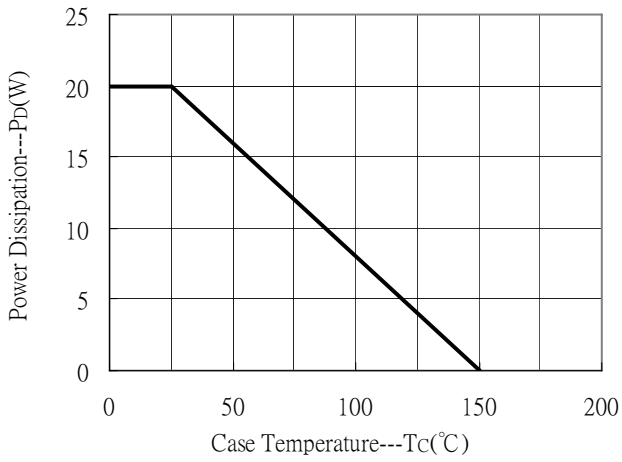

Reel Dimension

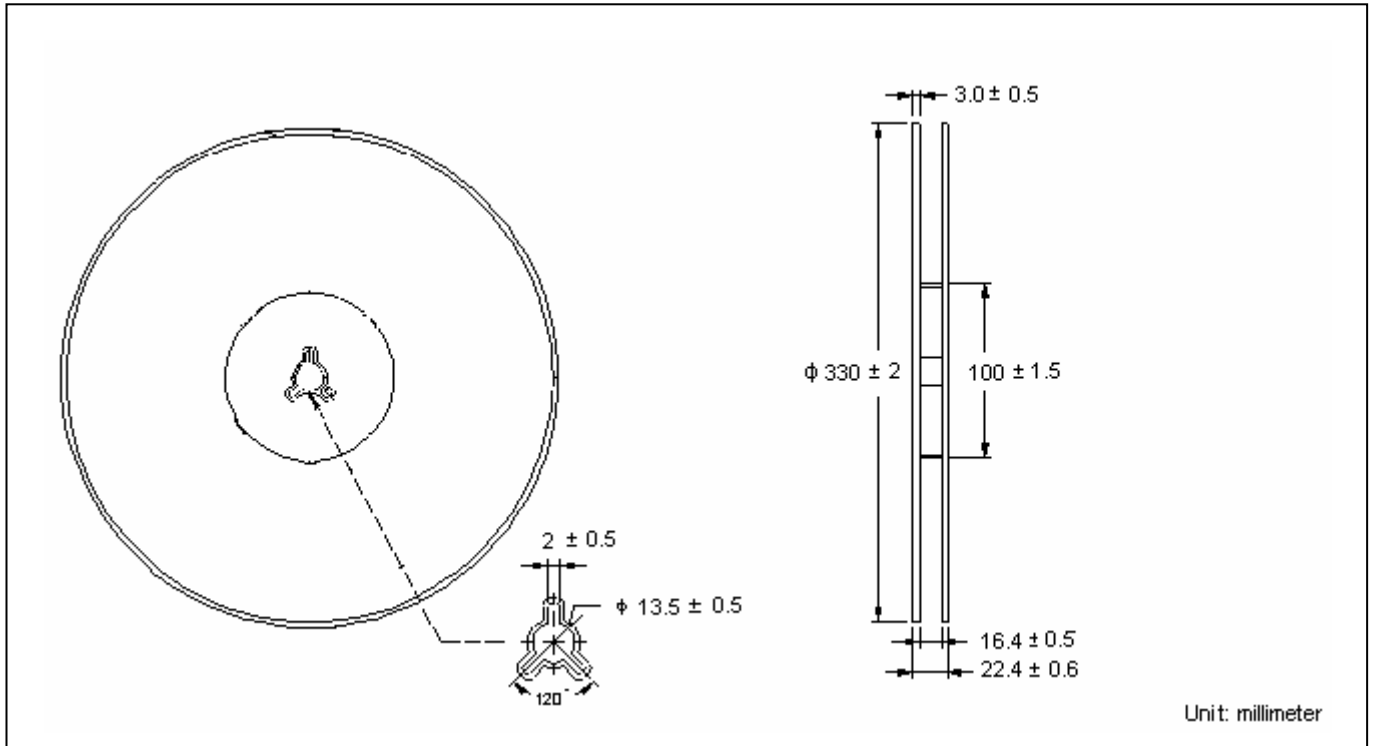

Carrier Tape Dimension

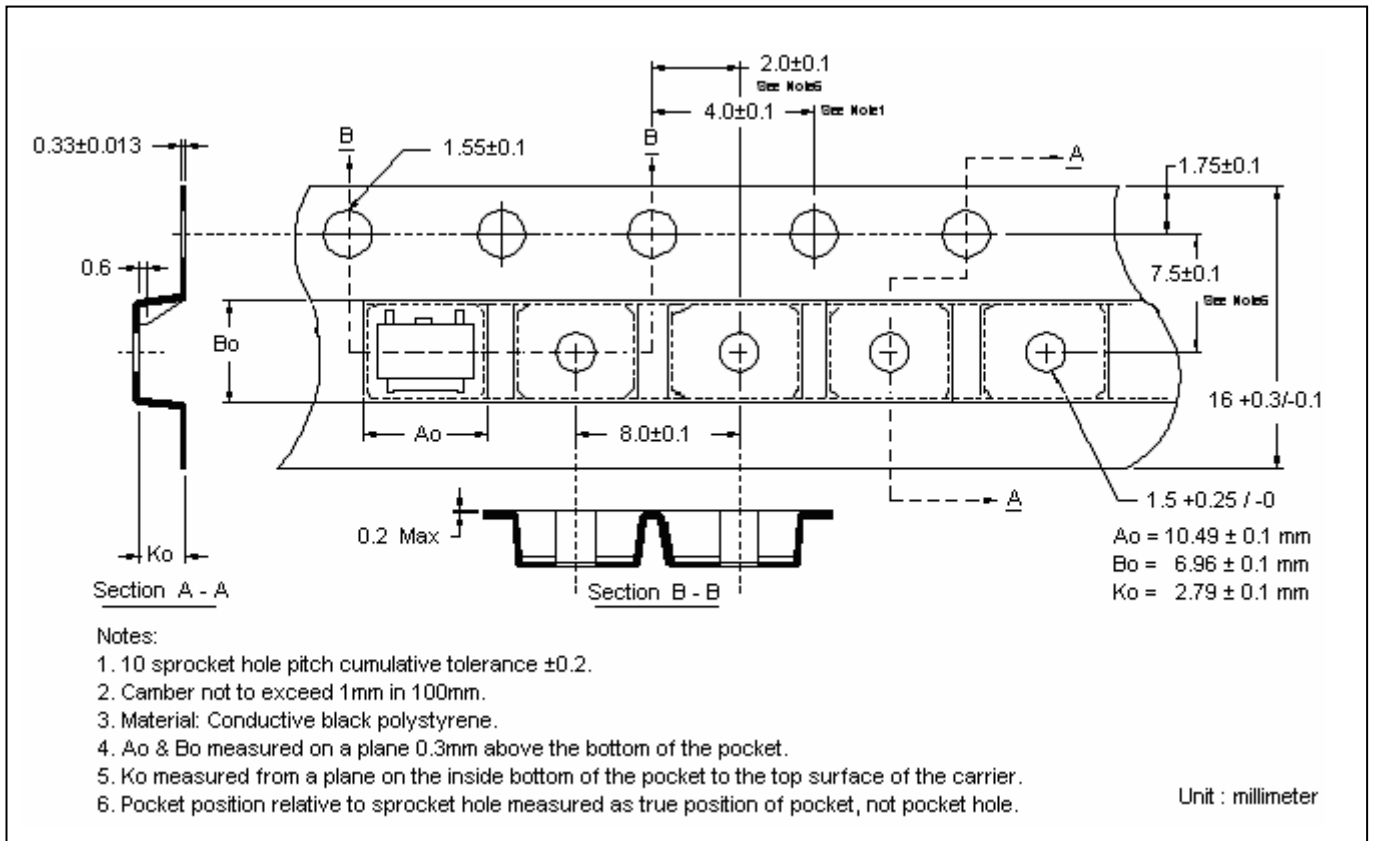

Recommended wave soldering condition

| | | |
|-----------------|------------------|-----------------|
| Product | Peak Temperature | Soldering Time |
| Pb-free devices | 260 +0/-5 °C | 5 +1/-1 seconds |

Recommended temperature profile for IR reflow

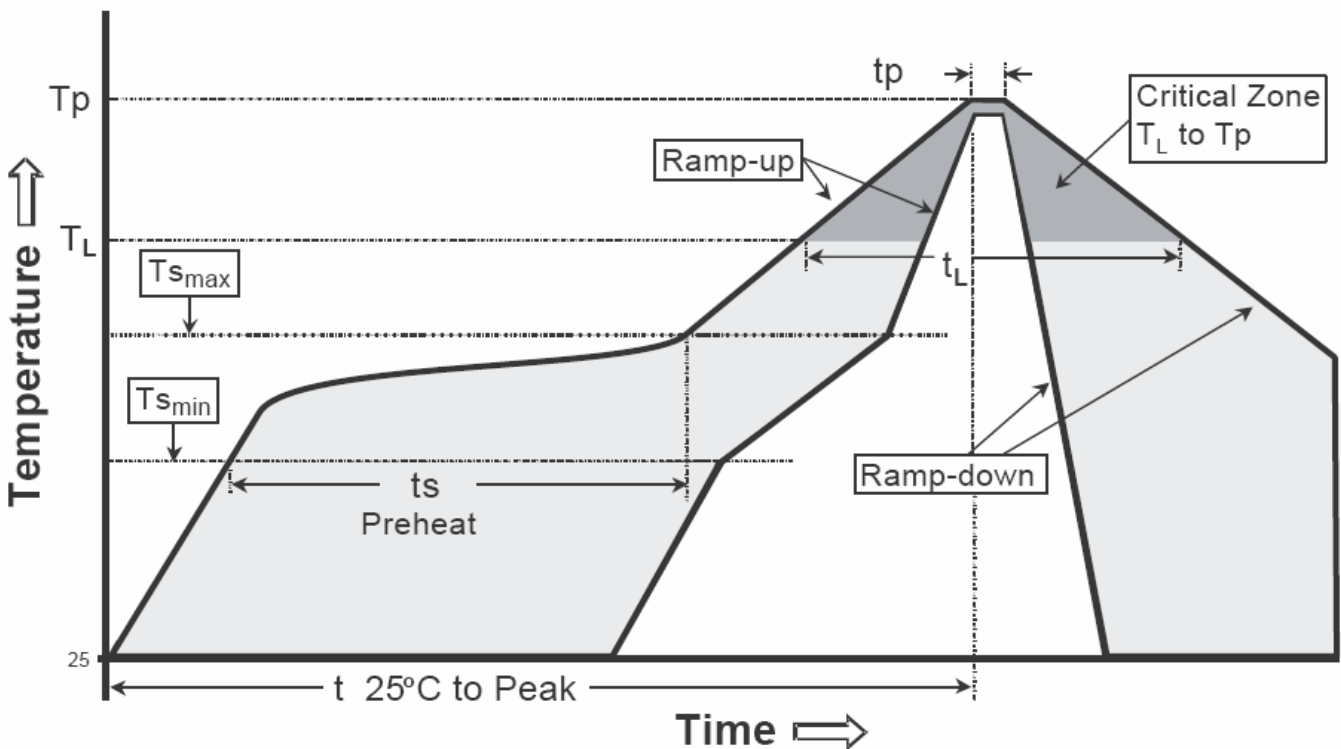

| Profile feature | Sn-Pb eutectic Assembly | Pb-free Assembly |
|---|-------------------------|------------------|
| Average ramp-up rate (T _{smax} to T _p) | 3°C/second max. | 3°C/second max. |
| Preheat | | |
| -Temperature Min(T _{s min}) | 100°C | 150°C |
| -Temperature Max(T _{s max}) | 150°C | 200°C |
| -Time(t _{s min} to t _{s max}) | 60-120 seconds | 60-180 seconds |
| Time maintained above: | | |
| -Temperature (T _L) | 183°C | 217°C |
| - Time (t _L) | 60-150 seconds | 60-150 seconds |
| Peak Temperature(T _P) | 240 +0/-5 °C | 260 +0/-5 °C |
| Time within 5°C of actual peak temperature(tp) | 10-30 seconds | 20-40 seconds |
| Ramp down rate | 6°C/second max. | 6°C/second max. |
| Time 25 °C to peak temperature | 6 minutes max. | 8 minutes max. |

TO-252 Dimension

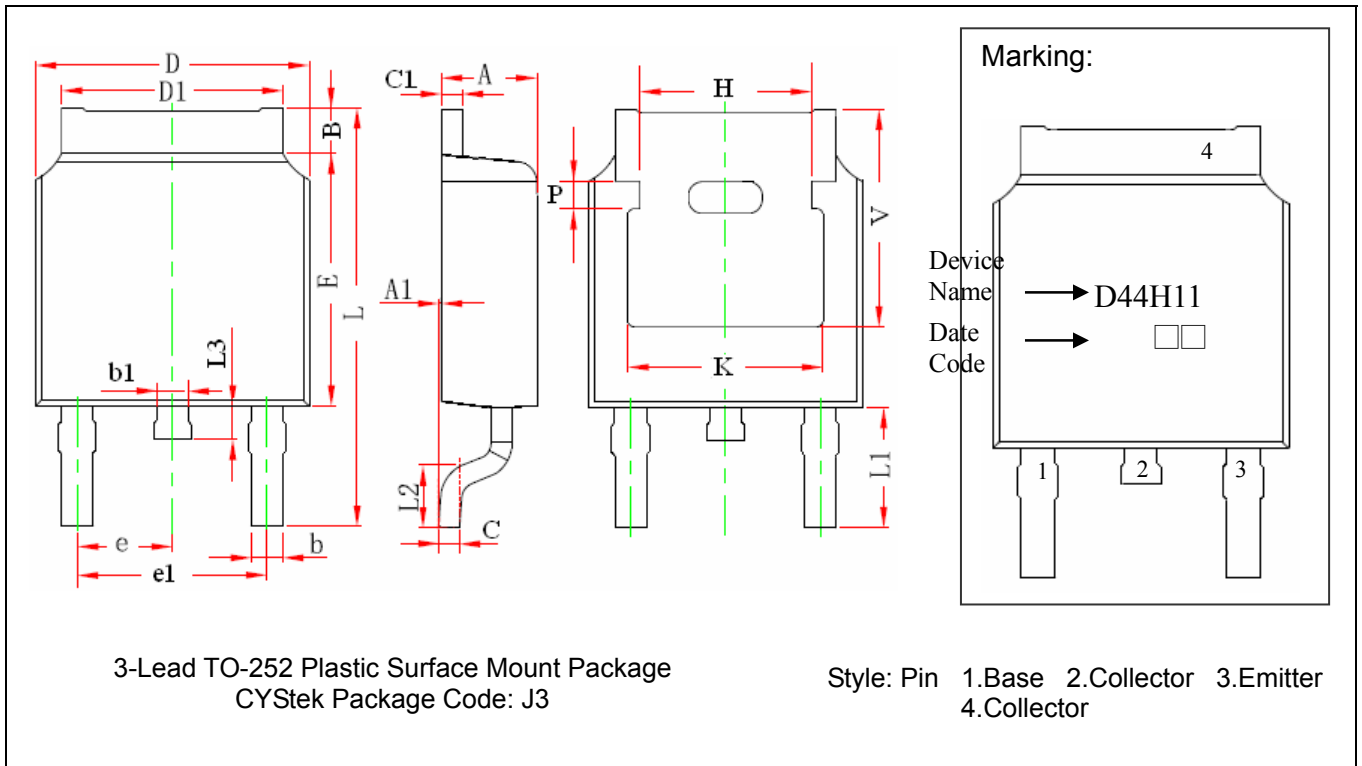

| DIM | Inches | | Millimeters | | DIM | Inches | | Millimeters | |
|-----|--------|-------|-------------|-------|-----|--------|-------|-------------|--------|
| | Min. | Max. | Min. | Max. | | Min. | Max. | Min. | Max. |
| A | 0.087 | 0.094 | 2.200 | 2.400 | e | 0.086 | 0.094 | 2.186 | 2.386 |
| A1 | 0.000 | 0.005 | 0.000 | 0.127 | e1 | 0.172 | 0.188 | 4.372 | 4.772 |
| B | 0.039 | 0.048 | 0.990 | 1.210 | H | 0.163 | REF | 4.140 | REF |
| b | 0.026 | 0.034 | 0.660 | 0.860 | K | 0.190 | REF | 4.830 | REF |
| b1 | 0.026 | 0.034 | 0.660 | 0.860 | L | 0.386 | 0.409 | 9.800 | 10.400 |
| C | 0.018 | 0.023 | 0.460 | 0.580 | L1 | 0.114 | REF | 2.900 | REF |
| C1 | 0.018 | 0.023 | 0.460 | 0.580 | L2 | 0.055 | 0.067 | 1.400 | 1.700 |
| D | 0.256 | 0.264 | 6.500 | 6.700 | L3 | 0.024 | 0.039 | 0.600 | 1.000 |
| D1 | 0.201 | 0.215 | 5.100 | 5.460 | P | 0.026 | REF | 0.650 | REF |
| E | 0.236 | 0.244 | 6.000 | 6.200 | V | 0.211 | REF | 5.350 | REF |

Notes: 1.Controlling dimension: millimeters.
 2.Maximum lead thickness includes lead finish thickness, and minimum lead thickness is the minimum thickness of base material.
 3.If there is any question with packing specification or packing method, please contact your local CYStek sales office.

Material:

- Lead : Pure tin plated.
- Mold Compound: Epoxy resin family, flammability solid burning class: UL94V-0.

Important Notice:

- All rights are reserved. Reproduction in whole or in part is prohibited without the prior written approval of CYStek.
- CYStek reserves the right to make changes to its products without notice.
- CYStek **semiconductor products are not warranted to be suitable for use in Life-Support Applications, or systems.**
- CYStek assumes no liability for any consequence of customer product design, infringement of patents, or application assistance.