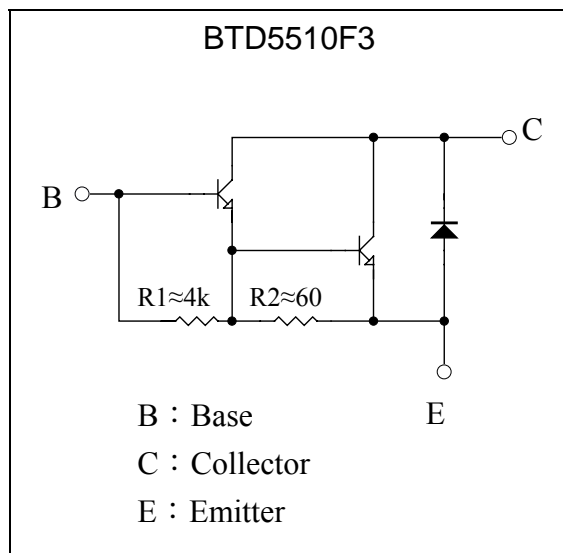
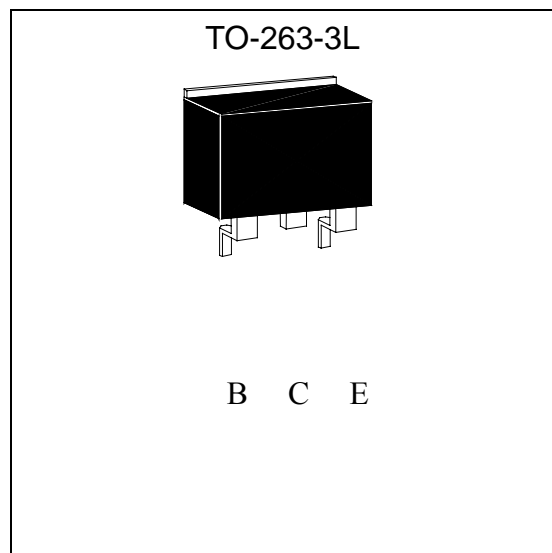

**NPN Epitaxial Planar Transistor****BTD5510F3****Description**

The BTD5510F3 is a NPN Darlington transistor, designed for general purpose amplifier and low speed switching application.

**Features:**

- High  $BV_{CEO}$
- Low  $V_{CE(SAT)}$
- High current gain
- Monolithic construction with built-in base-emitter shunt resistors
- Pb-free package

**Equivalent Circuit****Outline**



**Absolute Maximum Ratings** (Ta=25°C)

Parameter	Symbol	Limits	Unit
Collector-Base Voltage	V <sub>CBO</sub>	250	V
Collector-Emitter Voltage	V <sub>CEO</sub>	250	V
Emitter-Base Voltage	V <sub>EBO</sub>	10	V
Collector Current(DC)	I <sub>C</sub>	10	A
Collector Current(Pulse)	I <sub>CM</sub>	15 (Note 1)	
Power Dissipation	Pd(T <sub>A</sub> =25°C)	2	W
	Pd(T <sub>C</sub> =25°C)	60	
Thermal Resistance, Junction to Ambient	R <sub>θJA</sub>	62.5	°C/W
Thermal Resistance, Junction to Case	R <sub>θJC</sub>	2.08	°C/W
Junction Temperature	T <sub>j</sub>	150	°C
Storage Temperature	T <sub>stg</sub>	-55~+150	°C

Note : \*1. Single Pulse Pw=300μs

**Characteristics** (Ta=25°C)

Symbol	Min.	Typ.	Max.	Unit	Test Conditions
BV <sub>CBO</sub>	250	-	-	V	I <sub>C</sub> =100μA, I <sub>E</sub> =0
BV <sub>CEO</sub>	250	-	-	V	I <sub>C</sub> =1mA, I <sub>B</sub> =0
I <sub>CEO</sub>	-	-	100	μA	V <sub>CE</sub> =250V, I <sub>E</sub> =0
I <sub>CBO</sub>	-	-	100	μA	V <sub>CB</sub> =250V, I <sub>E</sub> =0
I <sub>EBO</sub>	-	-	2	mA	V <sub>EB</sub> =5V, I <sub>C</sub> =0
*V <sub>CE(sat)</sub> 1	-	-	1.4	V	I <sub>C</sub> =10A, I <sub>B</sub> =250mA
*V <sub>CE(sat)</sub> 2	-	-	1.3	V	I <sub>C</sub> =7A, I <sub>B</sub> =50mA
*V <sub>CE(sat)</sub> 3	-	-	1.0	V	I <sub>C</sub> =4A, I <sub>B</sub> =5mA
*V <sub>CE(sat)</sub> 4	-	-	1.2	V	I <sub>C</sub> =6A, I <sub>B</sub> =5mA
*V <sub>BE(sat)</sub>	-	-	2.0	V	I <sub>C</sub> =8A, I <sub>B</sub> =15mA
*V <sub>BE(on)</sub>	-	-	1.8	V	V <sub>CE</sub> =4V, I <sub>C</sub> =8A
*h <sub>FE</sub>	3000	-	-	-	V <sub>CE</sub> =4V, I <sub>C</sub> =5A

\*Pulse Test : Pulse Width ≤380μs, Duty Cycle≤2%

**Ordering Information**

Device	Package	Shipping	Marking
BTD5510F3	TO-263 (Pb-free)	800 pcs / Tape & Reel	D5510

**Characteristic curves**

Current Gain vs Collector Current

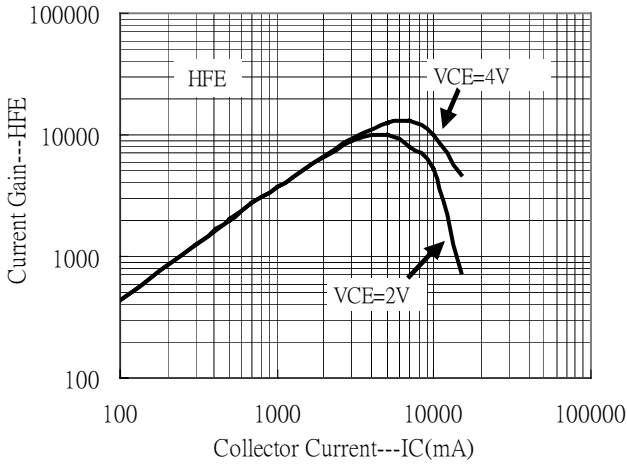

Saturation Voltage vs Collector Current

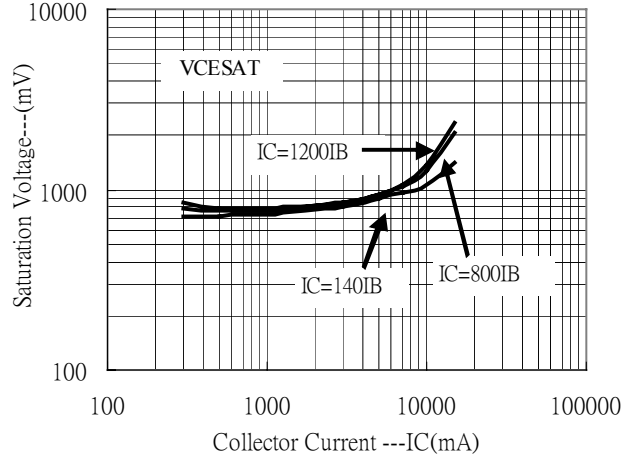

Saturation Voltage vs Collector Current

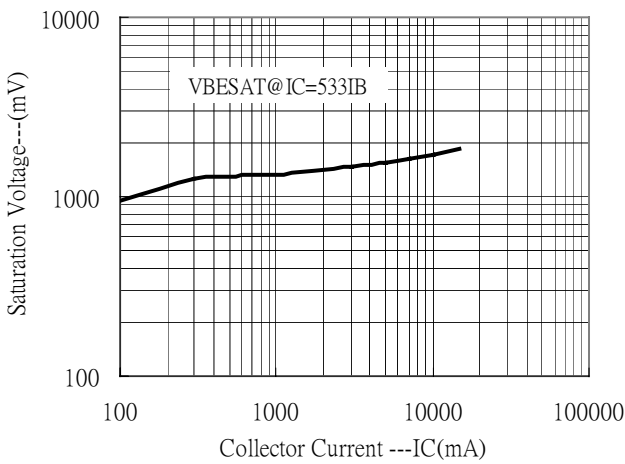

ON Voltage vs Collector Current

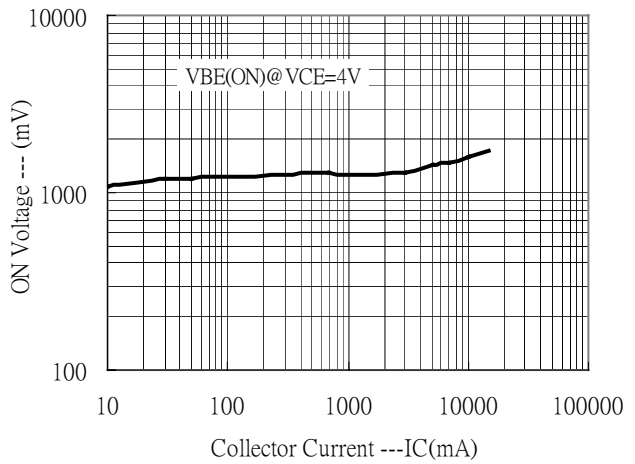

Power Derating Curve

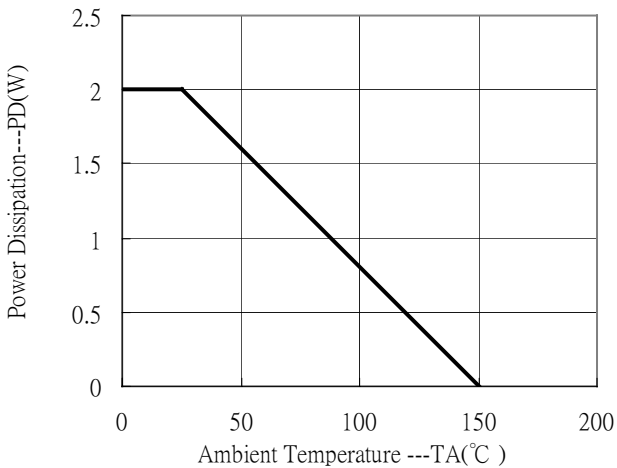

Power Derating Curve

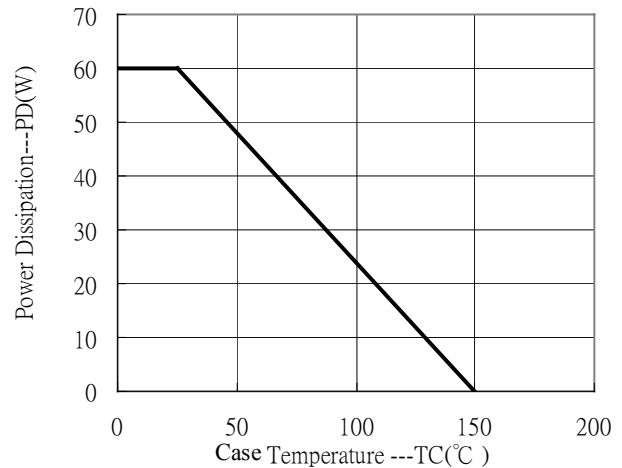

**TO-263 Dimension**

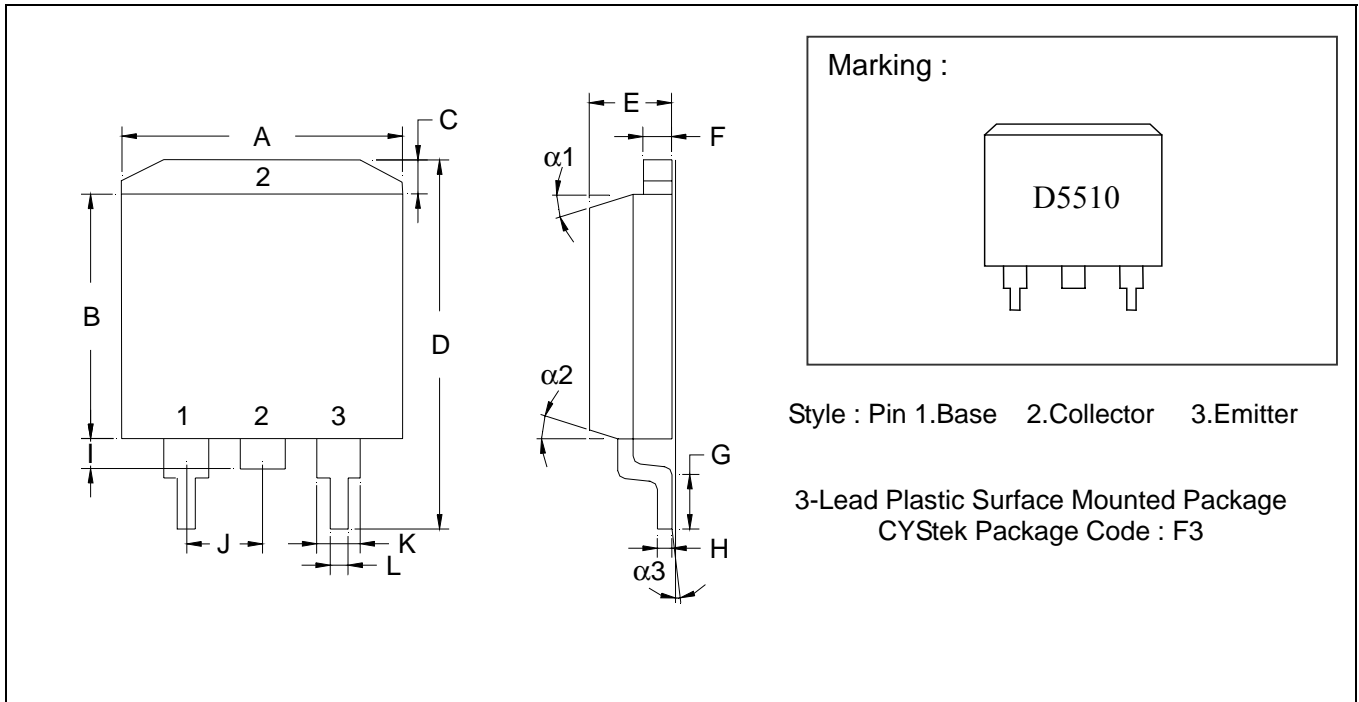

\*:Typical

DIM	Inches		Millimeters		DIM	Inches		Millimeters	
	Min.	Max.	Min.	Max.		Min.	Max.	Min.	Max.
A	0.3800	0.4050	9.65	10.29	I	0.0500	0.0700	1.27	1.78
B	0.3300	0.3700	8.38	9.40	J	-	*0.1000	-	*2.54
C	-	0.0550	-	1.40	K	0.0450	0.0550	1.14	1.40
D	0.5750	0.6250	14.61	15.88	L	0.0200	0.0390	0.51	0.99
E	0.1600	0.1900	4.06	4.83	$\alpha 1$	-	-	6°	8°
F	0.0450	0.0550	1.14	1.40	$\alpha 2$	-	-	6°	8°
G	0.0900	0.1100	2.29	2.79	$\alpha 3$	-	-	0°	5°
H	0.0180	0.0290	0.46	0.74					

Notes : 1.Controlling dimension : millimeters.  
 2.Maximum lead thickness includes lead finish thickness, and minimum lead thickness is the minimum thickness of base material.  
 3.If there is any question with packing specification or packing method, please contact your local CYStek sales office.

**Material :**

- Lead : 42 Alloy ; solder plating
- Mold Compound : Epoxy resin family, flammability solid burning class:UL94V-0

**Important Notice:**

- All rights are reserved. Reproduction in whole or in part is prohibited without the prior written approval of CYStek.
- CYStek reserves the right to make changes to its products without notice.
- CYStek **semiconductor products are not warranted to be suitable for use in Life-Support Applications, or systems.**
- CYStek assumes no liability for any consequence of customer product design, infringement of patents, or application assistance.