

T-39-11



2052A

N-Channel MOS
Silicon Field-Effect Transistor

Very High Speed Switching Applications

©2559

Features

- Low ON resistance, very high-speed switching

Absolute Maximum Ratings at Ta=25°C

			unit
Drain to Source Voltage	V_{DSS}	450	V
Gate to Source Voltage	V_{GSS}	±20	V
Drain Current (D.C)	I_D	2	A
Drain Current (pulse)	$I_{D peak}$	5	A
Allowable Power Dissipation	P_D	50	W
Junction Temperature	T_J	150	°C
Storage Temperature	T_{stg}	-55 to +150	°C

$T_c=25°C$

Electrical Characteristics at Ta=25°C

			min	typ	max	unit
D-S Breakdown Voltage	V_{DSS}	$I_D=1mA, V_{GS}=0$	450			V
D-S Cutoff Current	I_{DSS}	$V_{DS}=450V, V_{GS}=0$			1.0	mA
G-S Leakage Current	I_{GSS}	$V_{GS}=±20V, V_{DS}=0$			±100	nA
G-S Cutoff Current	$I_{GS(off)}$	$V_{DS}=10V, I_D=1mA$	1.5		4.0	V
Forward Transfer Admittance	$ y_{fs} $	$V_{DS}=10V, I_D=1A$	0.6	1.2		S
Saturation Resistance	$R_{DS(on)}$	$I_D=1A, V_{GS}=10V$	2.5	3.5		ohm
Input Capacitance	C_{iss}	$V_{DS}=20V, f=1MHz$		400		pF
Output Capacitance	C_{oss}	$V_{DS}=20V, f=1MHz$		50		pF
Reverse Transfer Capacitance	C_{rss}	$V_{DS}=20V, f=1MHz$		10		pF
Turn-on Delay Time	$t_{d(on)}$	$I_D=1A, V_{GS}=10V$ $V_{CC}=200V, R_{GS}=50ohms$		15	30	ns
Rise Time	t_r			15	30	ns
Turn-off Delay Time	$t_{d(off)}$			50	100	ns
Fall Time	t_f			25	50	ns

Switching Time Test Circuit

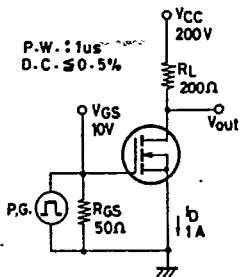

Case Outline 2052A
(unit:mm)

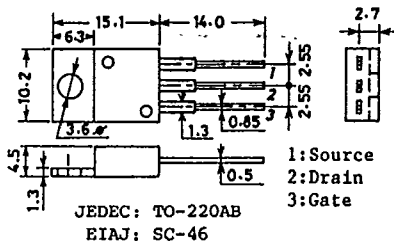

Note: Be careful in handling the 2SK775 because it has no protect diode between gate and source.

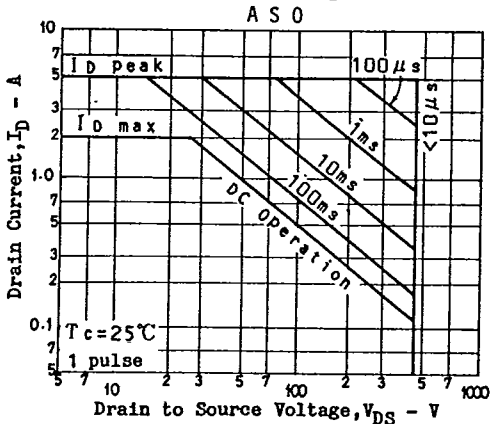
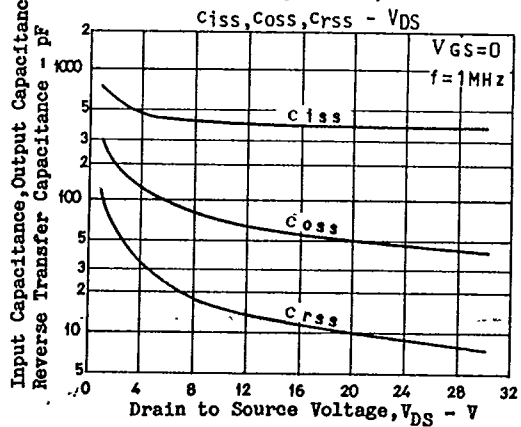
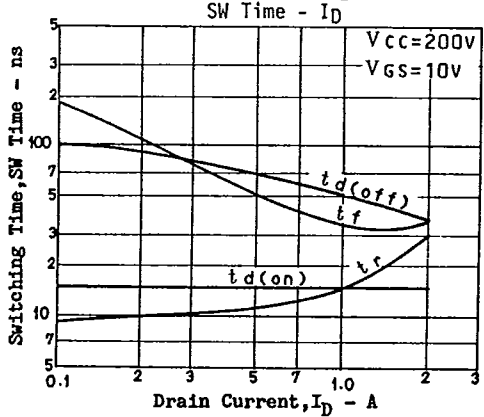
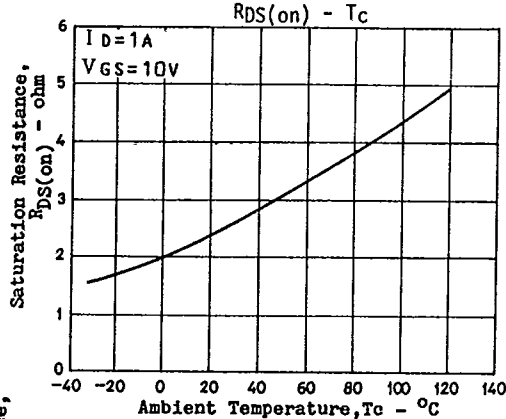
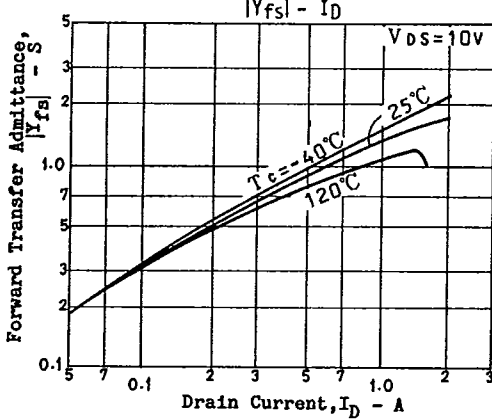
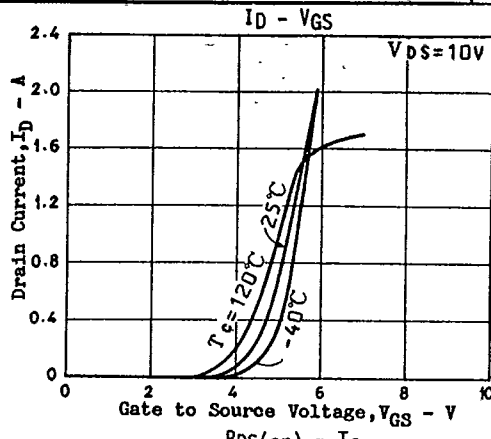
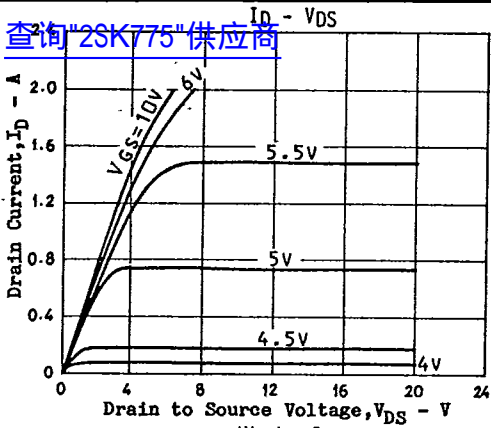

T-91-20

CASE OUTLINES AND ATTACHMENTS

[查询"2SK775"供应商](#)

- All of Sanyo Transistor case outlines are illustrated below.
- All dimensions are in mm, and dimensions which are not followed by min. or max. are represented by typical values.
- No marking is indicated.

Case Outline-[2003A]

unit:mm

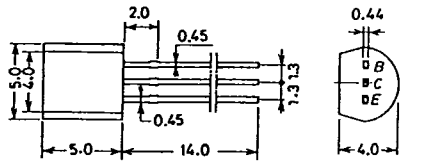

JEDEC: TO-92
EIAJ: SC-43
SANYO: NP

B. Base
C. Collector
E. Emitter

Case Outline-[2009A]

unit:mm

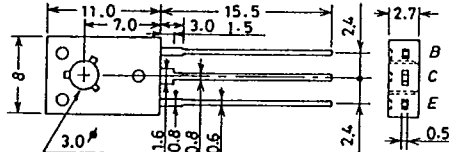

JEDEC: TO-126

B: Base
C: Collector
E: Emitter

Case Outline-[2004A]

unit:mm

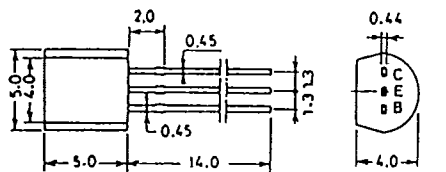

JEDEC: TO-92
EIAJ: SC-43
SANYO: NP

C. Collector
E. Emitter
B. Base

Case Outline-[2010A]

unit:mm

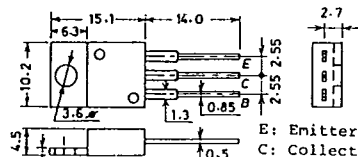

JEDEC: TO-220AB
EIAJ: SC-46

E: Emitter
C: Collector
B: Base

Case Outline-[2005A]

unit:mm

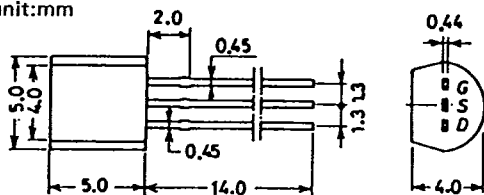

JEDEC: TO-92
EIAJ: SC-43
SANYO: NP

G: Gate
S: Source
D: Drain

Case Outline-[2012]

unit:mm

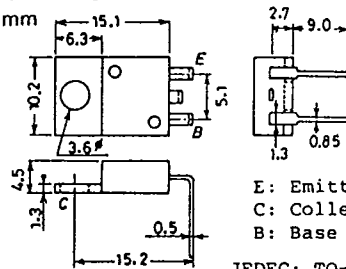

JEDEC: TO-220AA
EIAJ: SC-45

E: Emitter
C: Collector
B: Base

Case Outline-[2006A]

unit:mm

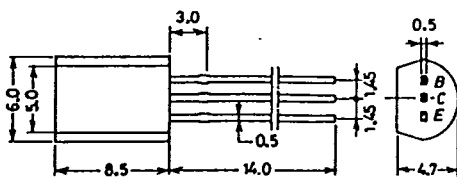

EIAJ: SC-51
SANYO: MP

B: Base
C: Collector
E: Emitter

Case Outline-[2013]

unit:mm

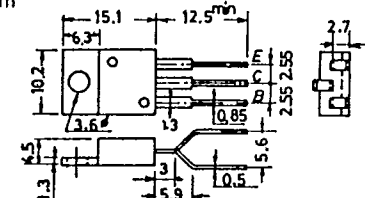

JEDEC TO-220

B: Base
C: Collector
E: Emitter

Case Outline-[2017]

unit:mm

[查询"2SK775"供应商](#)

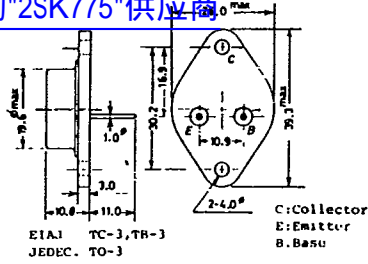

Case Outline-[2025]

unit:mm

T-91-20

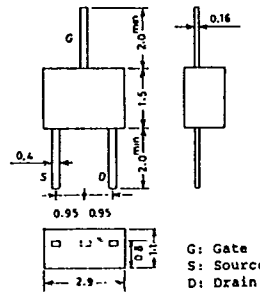

Case Outline-[2018A]

unit:mm

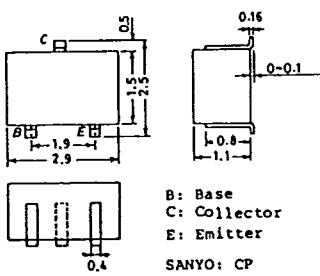

Case Outline-[2026]

unit:mm

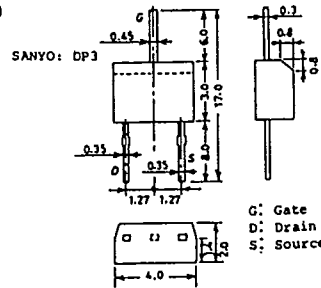

Case Outline-[2019A]

unit:mm

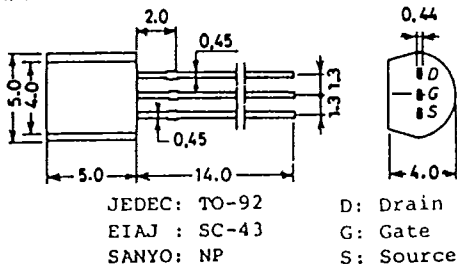

Case Outline-[2027A]

unit:mm

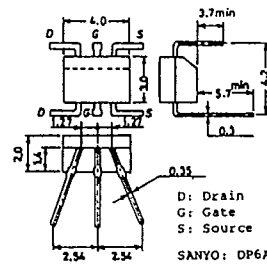

Case Outline-[2022]

unit:mm

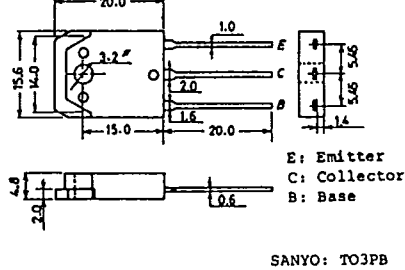

Case Outline-[2028A]

unit:mm

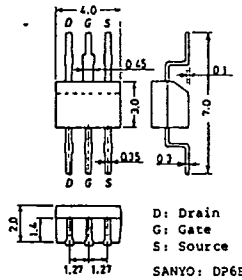

Case Outline-[2024A]

unit:mm

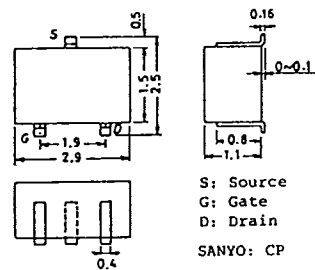

Case Outline-[2029A]

unit:mm

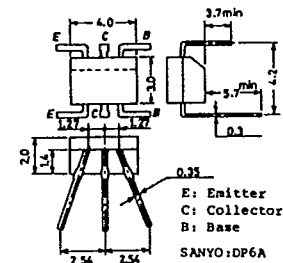

T-91-20

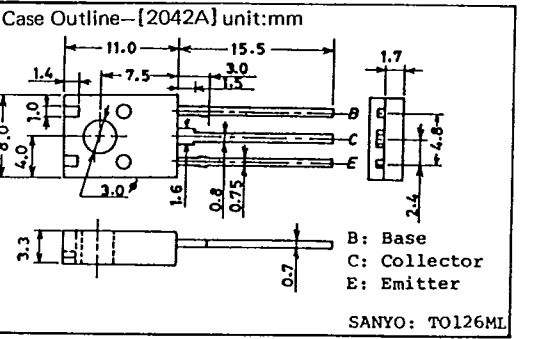
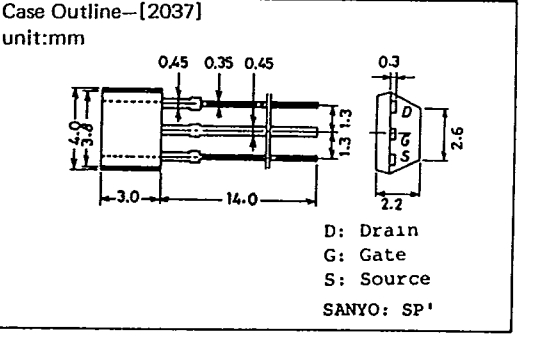
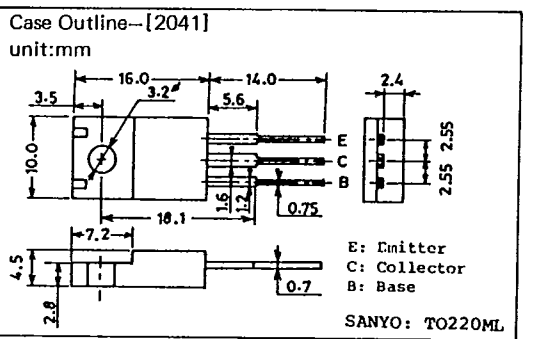
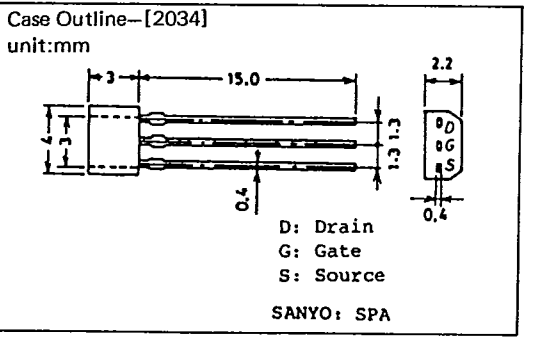
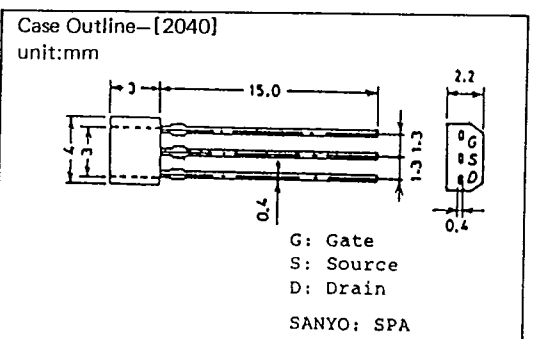
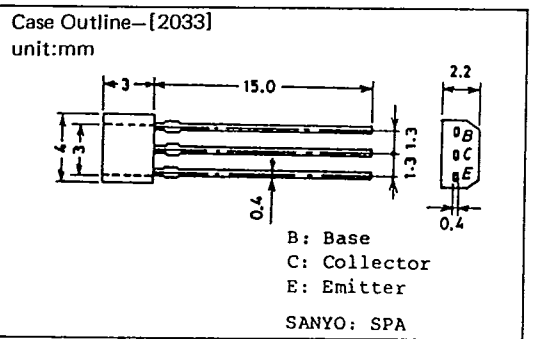
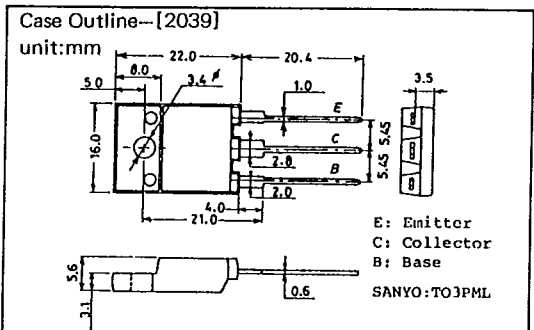
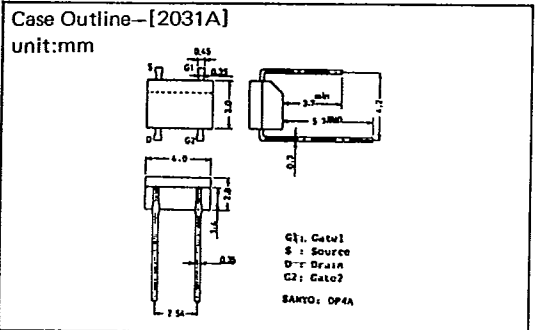
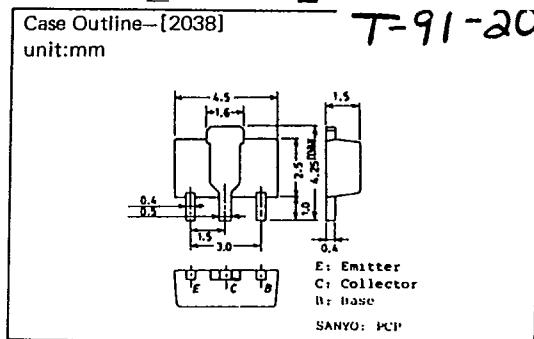
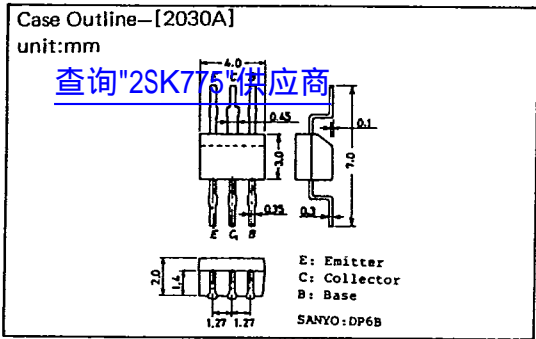

T-91-20

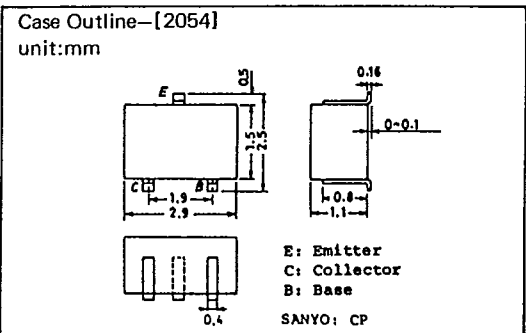
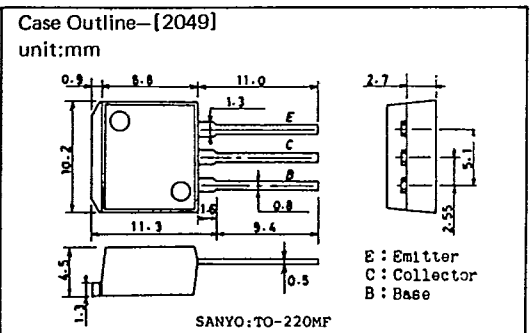
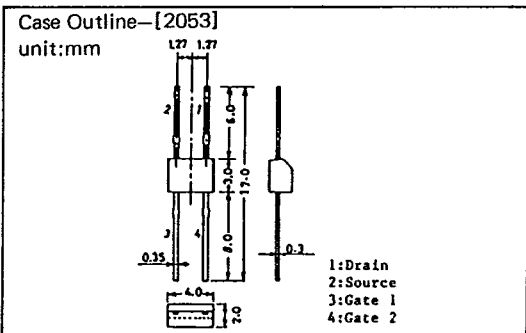
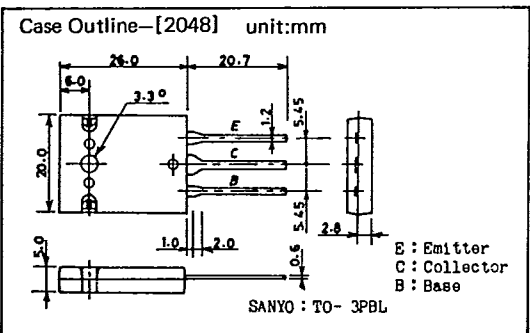
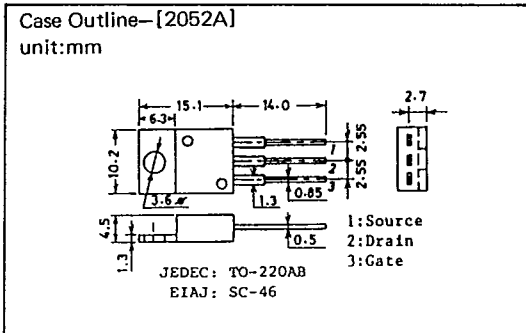
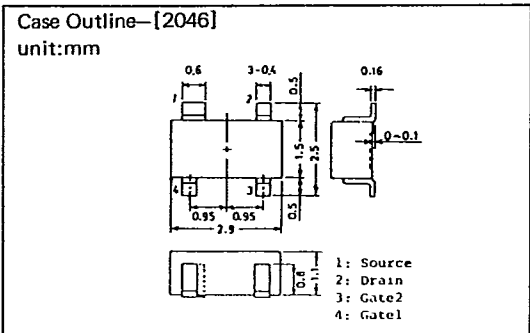
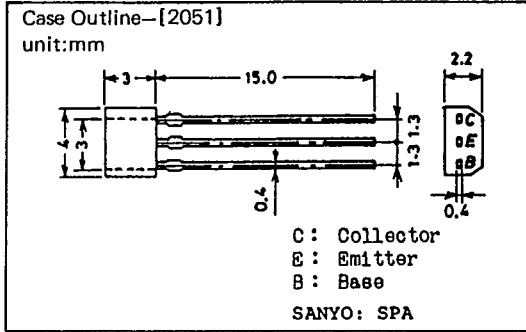
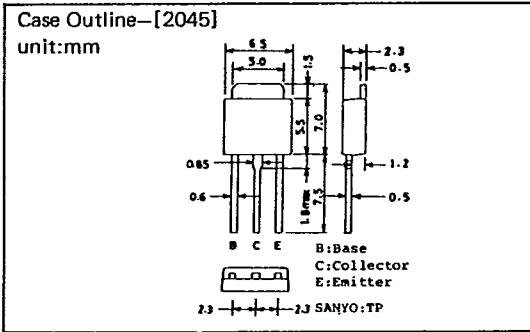
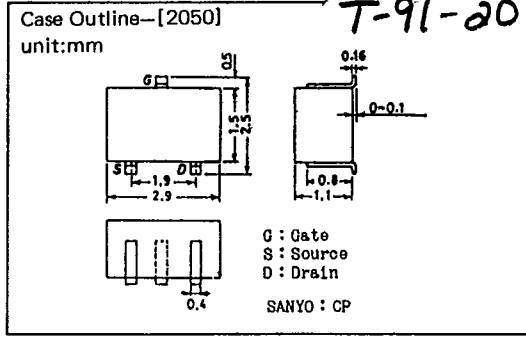
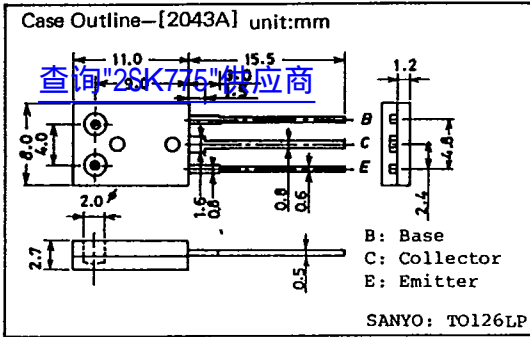

T-91-20

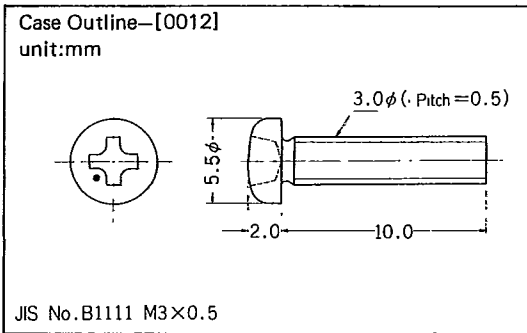
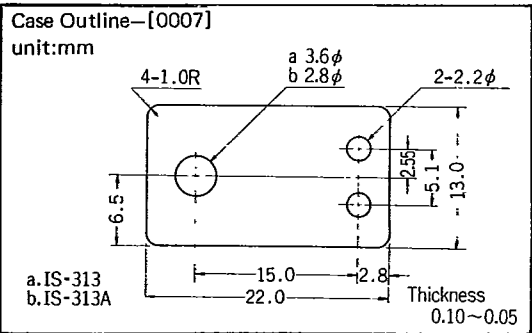
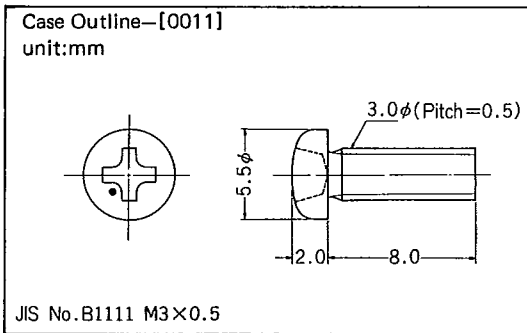
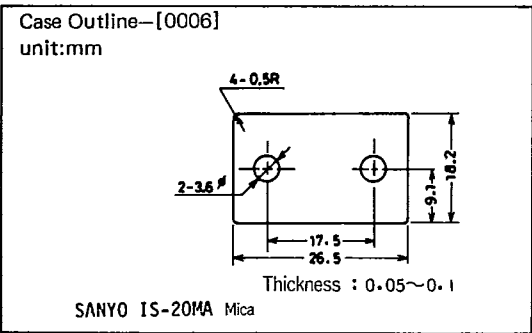
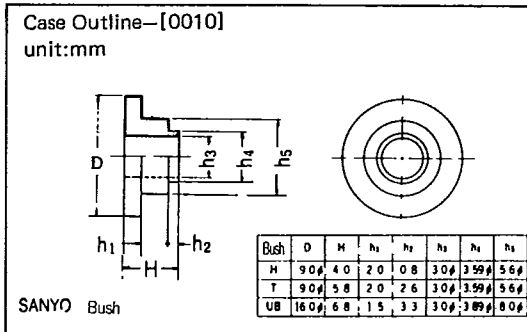
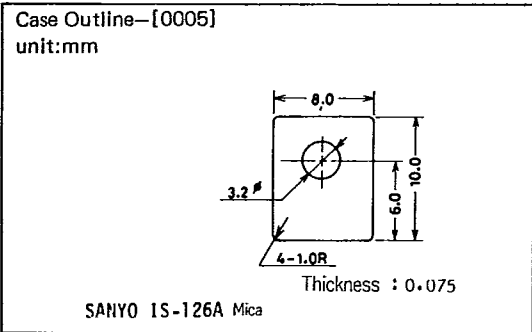
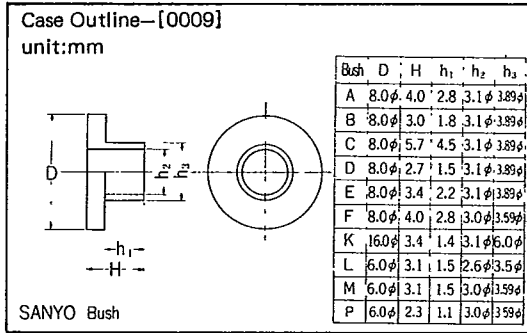
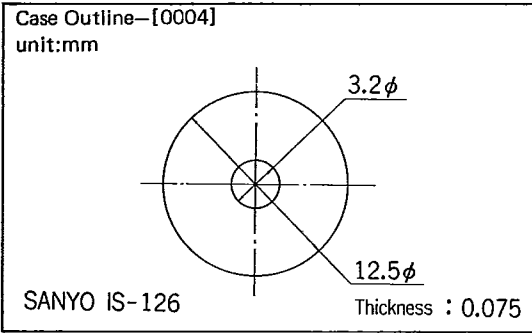
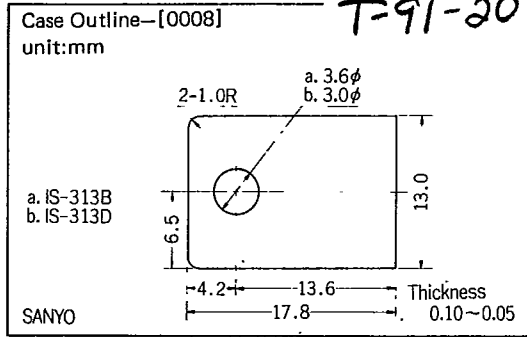
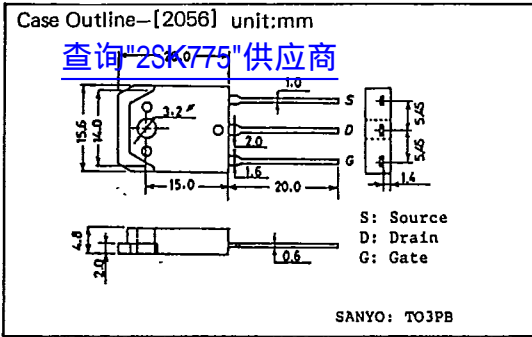

Case Outline-[0013]

unit:mm
[查询"2SK775"供应商](#)

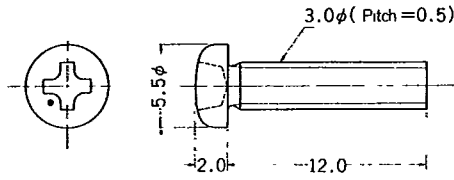

JIS No. B1111 M3×0.5

Case Outline-[0018]

unit:mm

T-91-20

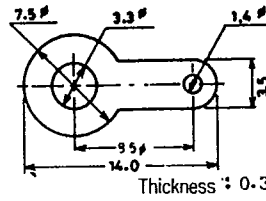

SANYO Lug 1.4

Case Outline-[0014]

unit:mm

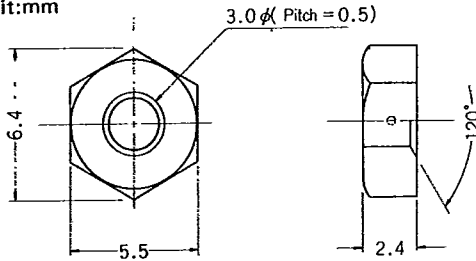

JIS No. B1181 M3×0.5

Case Outline-[0019]

unit:mm

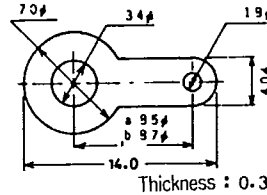

SANYO Lug 1.8φ

Case Outline-[0015]

unit:mm

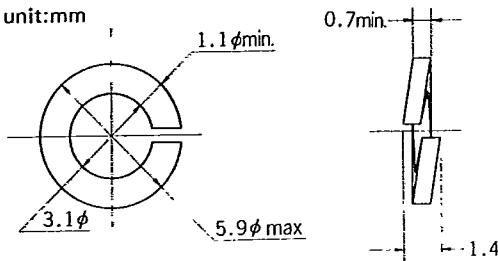

JIS No. B 1251 Spring washer (M3)

Case Outline-[0020]

unit:mm

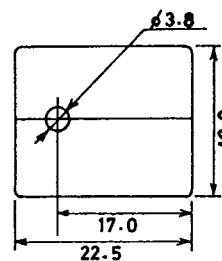

SANYO IS-3MP Mica

Case Outline-[0016]

unit:mm

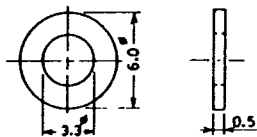

JIS No. B1252 Flat washer

Case Outline-[0021]

unit:mm

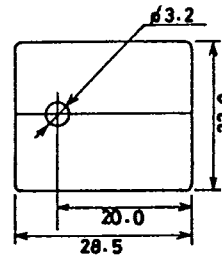

SANYO IS-MPC Mica

Case Outline-[0017]

unit:mm

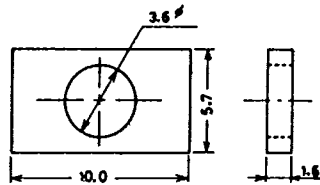

JIS No. G3141 Rectangular washer

Case Outline-[0022]

unit:mm

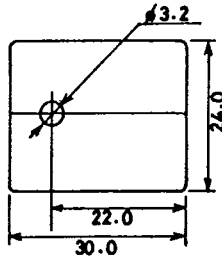

SANYO IS-3PBL Mica