

Features

- Isolation voltage 3000 V~
- Industrial Standard Package
- High Surge Capability
- Glass Passivated Chips
- Simple Mounting
- Electrically Isolated by DBC Ceramic



Applications

- DC Motor Control and Drives
- Battery Charges
- Welders
- Power Converters
- Lighting Control
- Heat and Temperature Control

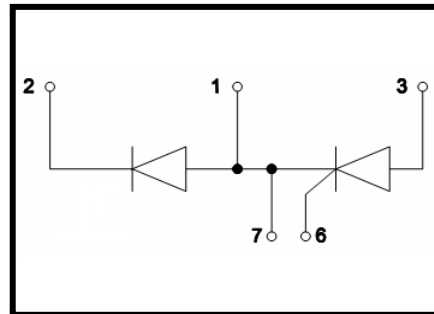

Advantages

- Space and weight savings
- Improved temperature and power cycling

■ Diode

ABSOLUTE MAXIMUM RATINGS

$T_C=25^{\circ}\text{C}$ unless otherwise specified

Symbol	Test Condition	Value	Unit
V_{RRM}		1600	V
$I_{d(AV)}$	$T_C=100^{\circ}\text{C}$, module	60	A
I_{FSM}	$T_J=45^{\circ}\text{C}$; $t=10\text{ms}$ (50Hz),sine	1450	A
	$V_R=0$ $t=8.3\text{ms}$ (60Hz),sine	1580	A
I^2t	$T_J=45^{\circ}\text{C}$; $t=10\text{ms}$ (50Hz),sine	10.5	KA^2s
	$V_R=0$ $t=8.3\text{ms}$ (60Hz),sine	10.4	
T_J	Junction Temperature	-40~150	$^{\circ}\text{C}$

ELECTRICAL AND THERMAL CHARACTERISTICS $T_C=25^\circ\text{C}$ unless otherwise specified

Symbol	Test Condition	Value	Unit
I_R	$V_R = V_{RRM}; T_J = 25^\circ\text{C}$	≤ 0.5	mA
	$V_R = V_{RRM}; T_J = T_{JM}$	≤ 5	mA
V_F	$I_F = 200\text{A}$	1.30	V
V_{T0}	For power-loss calculations only	0.8	V
R_{thJC}	Thermal Resistance, Junction-to-Case	0.45	K/W
R_{thCS}	Thermal Resistance, Case -to-Sink	0.10	K/W

■ Thyristor

ABSOLUTE MAXIMUM RATINGS $T_C=25^\circ\text{C}$ unless otherwise specified

Symbol	Test Condition	Value	Unit
V_{RRM} / V_{DRM}		1600	V
$I_{T(AV)}$	$T_C=85^\circ\text{C}$, 180° conduction, half sine wave;	60	A
$I_{T(RMS)}$	as AC switch;	135	A
I_{TSM}	$T_J=45^\circ\text{C}$, t=10ms (50Hz), sine, $V_R=0$;	1310	A
	$T_J=45^\circ\text{C}$, t=8.3 ms (60Hz), sine, $V_R=0$;	1370	
	$T_J=45^\circ\text{C}$, t=10ms (50Hz), sine, $V_R=V_{RRM}$;	1100	
	$T_J=45^\circ\text{C}$, t=8.3 ms (60Hz), sine, $V_R=V_{RRM}$;	1150	
i^2t	$T_J=45^\circ\text{C}$, t=10ms (50Hz), sine, $V_R=0$;	8.6	K A ² s
	$T_J=45^\circ\text{C}$, t=8.3 ms (60Hz), sine, $V_R=0$;	7.8	
	$T_J=45^\circ\text{C}$, t=10ms (50Hz), sine, $V_R=V_{RRM}$;	6.1	
	$T_J=45^\circ\text{C}$, t=8.3 ms (60Hz), sine, $V_R=V_{RRM}$;	5.5	
I_{DRM} / I_{RRM}	$V_R=V_{RRM}$, $V_D=V_{DRM}$, gate open circuit;	0.5	mA
	$T_J=125^\circ\text{C}$, $V_R=V_{RRM}$, $V_D=V_{DRM}$, gate open circuit;	15	mA
dV/dt	$T_J=125^\circ\text{C}$, exponential to 67% rated V_{DRM}	1000	V/us
V_{ISOL}	50Hz, all terminals shorted, t=1min, $I_{ISOL} \leq 1\text{mA}$;	3000	V~
T_J	Max. junction operating temperature range	-40~125	°C
T_{STG}	Max. storage temperature range	-40~125	°C

ELECTRICAL CHARACTERISTICS $T_C=25^{\circ}\text{C}$ unless otherwise specified

Symbol	Test Condition	Min.	Typ.	Max.	Unit
V_{TO}	$16.7\% \times \pi \times I_{AV} < I < \pi \times I_{AV}, T_J = 125^{\circ}\text{C};$			0.85	V
	$I > \pi \times I_{AV}, T_J = 125^{\circ}\text{C};$			0.88	V
r_t	$16.7\% \times \pi \times I_{AV} < I < \pi \times I_{AV}, T_J = 125^{\circ}\text{C};$			3.53	m Ω
	$I > \pi \times I_{AV}, T_J = 125^{\circ}\text{C};$			3.41	m Ω
I_H	$V_{AK} = 6\text{V}$, resistive load;			200	mA
I_L	Anode supply = 6V, resistive load = 1 Ω , gate pulse = 10V, 100 μs ;			400	mA
V_{TM}	$I_{TM} = 200\text{A}$, $t_d = 10\text{ ms}$, half sine		1.30	1.80	V
P_{GM}	$t_p \leq 5\text{ms}$, $T_J = 125^{\circ}\text{C};$			10	W
$P_{GM(AV)}$	$f = 50\text{Hz}$, $T_J = 125^{\circ}\text{C};$			2.5	W
I_{GM}	$t_p \leq 5\text{ms}$, $T_J = 125^{\circ}\text{C};$			2.5	A
$-V_{GT}$				10	V
V_{GT}	$V_A = 6\text{V}$, $R_A = 1\Omega$, $T_J = -40^{\circ}\text{C};$			4	V
	$V_A = 6\text{V}$, $R_A = 1\Omega;$			2.5	
	$V_A = 6\text{V}$, $R_A = 1\Omega$, $T_J = 125^{\circ}\text{C};$			1.7	
I_{GT}	$V_A = 6\text{V}$, $R_A = 1\Omega$, $T_J = -40^{\circ}\text{C};$			270	mA
	$V_A = 6\text{V}$, $R_A = 1\Omega;$			150	
	$V_A = 6\text{V}$, $R_A = 1\Omega$, $T_J = 125^{\circ}\text{C};$			80	
V_{GD}	$V_{AK} = V_{DRM}$, $T_J = 125^{\circ}\text{C}$			0.25	V
I_{GD}				6	mA
di/dt	$T_J = 25^{\circ}\text{C}$, $V_D = 0.67V_{DRM}$, $I_{TM} = 345\text{A}$, $I_g = 500\text{mA}$, $t_r < 0.5\ \mu\text{s}$, $t_p > 6\ \mu\text{s}$			150	A/ μs

THERMAL AND MECHANICAL CHARACTERISTICS $T_C=25^{\circ}\text{C}$ unless otherwise specified

Symbol	Test Condition	value	Unit
R_{thjc}	Thermal Resistance , Junction-to-Case	0.45	K/W
R_{THCS}	Thermal Resistance, Case -to-Sink	0.10	K/W
Md	Mounting torque(M5)	3 to 5	N·m
	Terminal connection torque(M5)		
Weight	Typical value	105	g

Characteristic curves

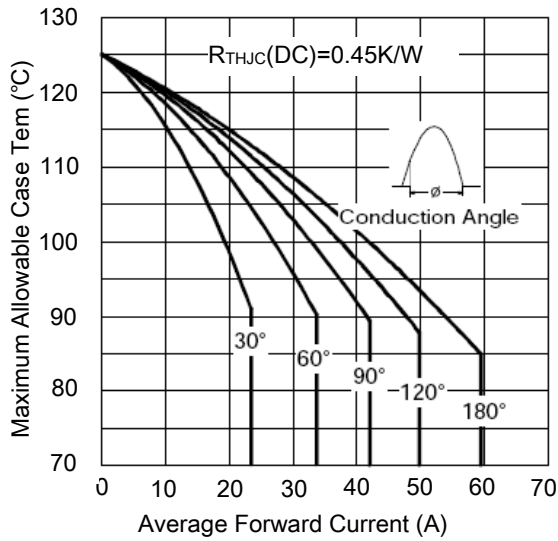

Figure 1. Current Rating Characteristics

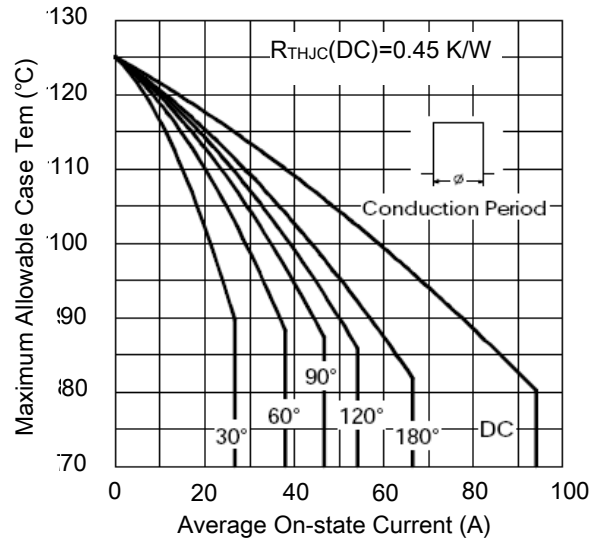

Figure 2. Current Rating Characteristics

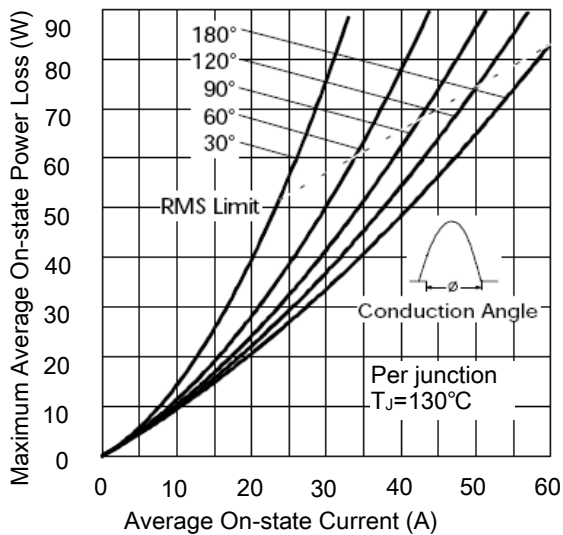

Figure 3. On-state Power Loss Characteristics

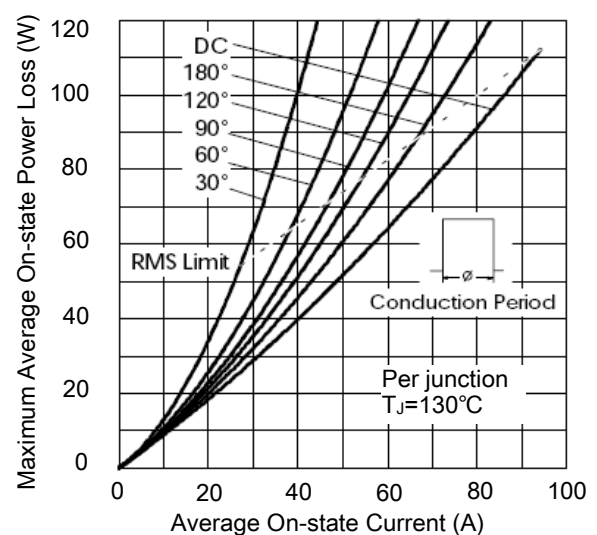

Figure 4. On-state Power Loss Characteristics

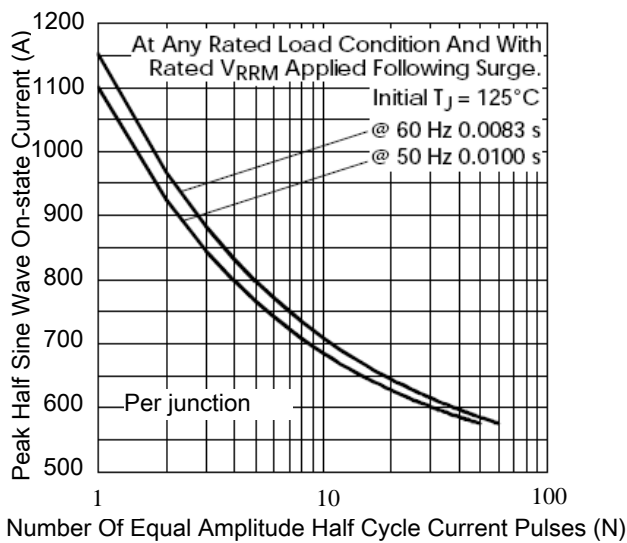

Figure 5. Maximum Non-Repetitive Surge Current

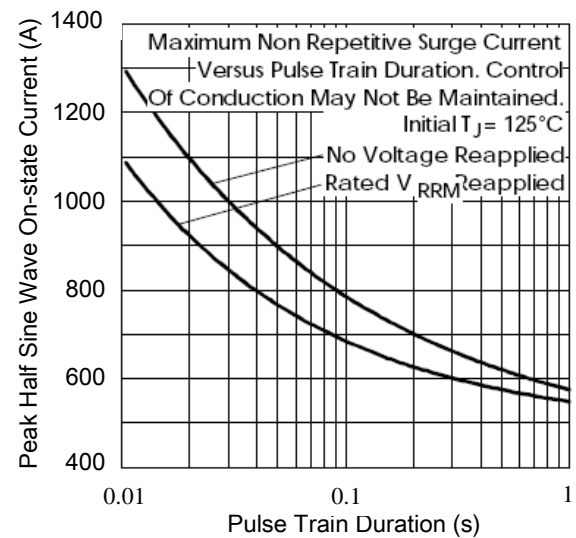

Figure 6. Maximum Non-Repetitive Surge Current

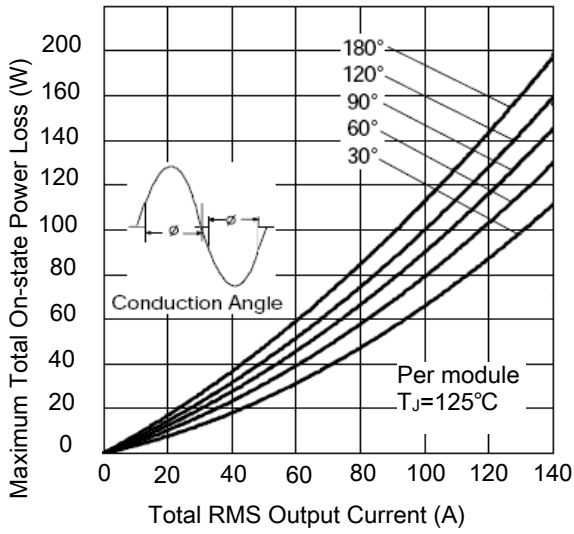

Figure 7. On-State Power Loss Characteristics-1

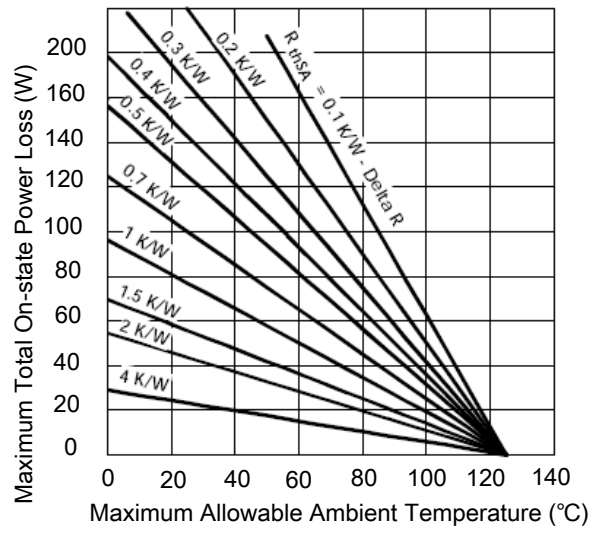

Figure 8. On-State Power Loss Characteristics-2

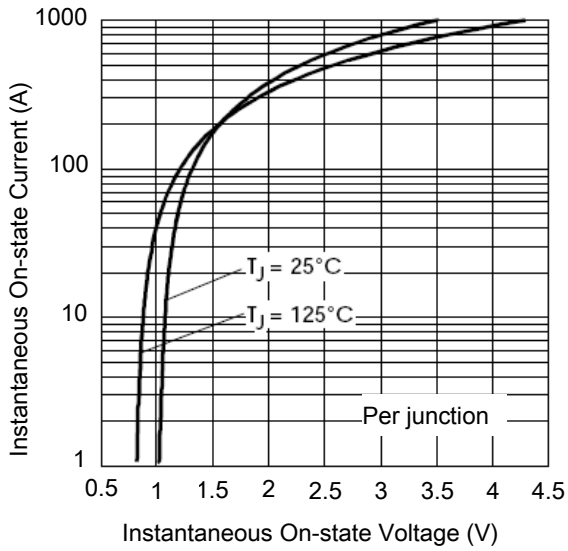

Figure 9. On-state Voltage Drop Characteristics

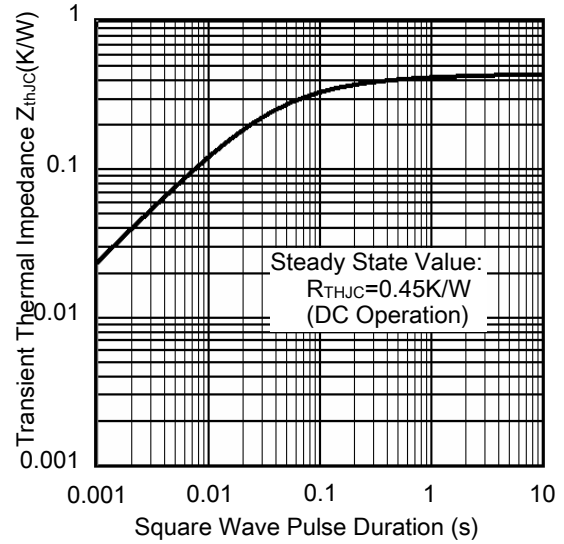

Figure 10. Thermal Impedance Z_{thJC} Characteristics

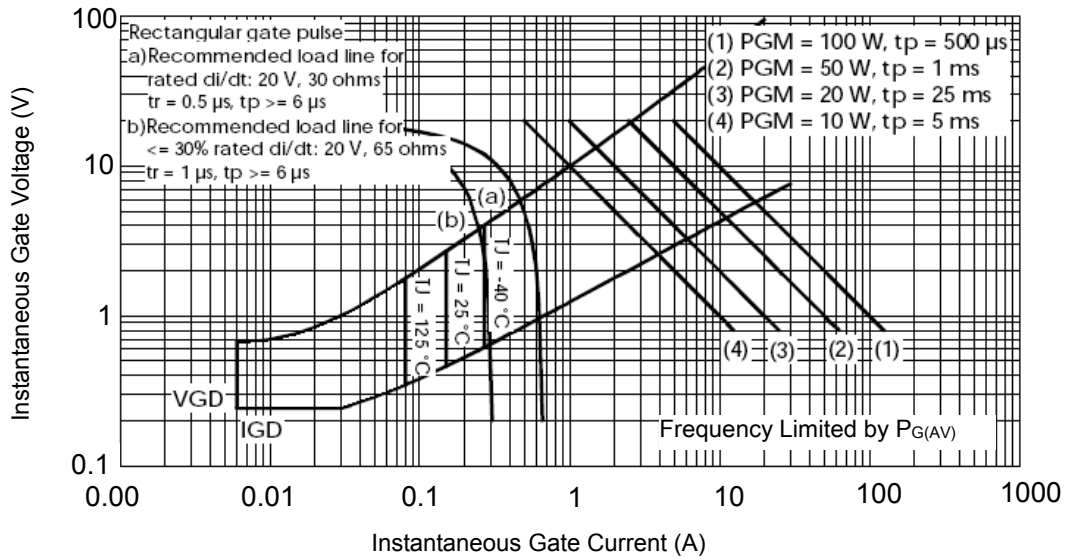

Figure.11 Gate Characteristics

Package Outline (Dimensions in mm)

