

PRODUCT FEATURES

- Ultrafast Recovery Time
- Soft Recovery Characteristics
- Low Recovery Loss
- Low Forward Voltage
- High Surge Current Capability
- Low Leakage Current

APPLICATIONS

- Freewheeling, Snubber, Clamp
- Inversion Welder
- PFC
- Plating Power Supply
- Ultrasonic Cleaner and Welder
- Converter & Chopper
- UPS

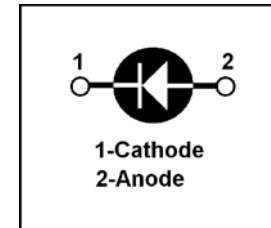
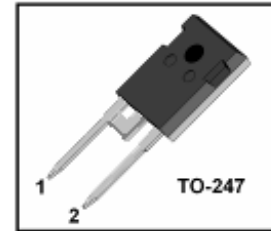

DESCRIPTION

FRED from MacMic utilizes advanced processing techniques to achieve ultrafast recovery times and higher forward current. Its soft recovery characteristics and high reliability suit for wide industrial applications.

ABSOLUTE MAXIMUM RATINGS

$T_C=25^\circ\text{C}$ unless otherwise specified

| Symbol | Parameter | Test Conditions | Values | Unit |
|-----------------|--------------------------------------|---|-------------|---------------------------|
| V_R | Maximum D.C. Reverse Voltage | | 1200 | V |
| V_{RRM} | Maximum Repetitive Reverse Voltage | | 1200 | V |
| $I_{F(AV)}$ | Average Forward Current | $T_C=110^\circ\text{C}$ | 30 | A |
| $I_{F(RMS)}$ | RMS Forward Current | $T_C=110^\circ\text{C}$ | 45 | A |
| I_{FSM} | Non-Repetitive Surge Forward Current | $T_J=45^\circ\text{C}$, $t=10\text{ms}$, 50Hz, Sine | 300 | A |
| P_D | Power Dissipation | | 105 | W |
| T_J | Junction Temperature | | -40 to +150 | $^\circ\text{C}$ |
| T_{STG} | Storage Temperature Range | | -40 to +150 | $^\circ\text{C}$ |
| Torque | Module-to-Sink | Recommended (M3) | 1.1 | N·m |
| $R_{\theta JC}$ | Thermal Resistance | Junction-to-Case | 1.2 | $^\circ\text{C}/\text{W}$ |
| Weight | | | 2.2 | g |

ELECTRICAL CHARACTERISTICS

$T_C=25^\circ\text{C}$ unless otherwise specified

| Symbol | Parameter | Test Conditions | Min. | Typ. | Max. | Unit |
|-----------|-------------------------------|--|------|------|------|---------------|
| I_{RM} | Reverse Leakage Current | $V_R=1200\text{V}$ | -- | -- | 100 | μA |
| | | $V_R=1200\text{V}$, $T_J=125^\circ\text{C}$ | -- | -- | 500 | μA |
| V_F | Forward Voltage | $I_F=30\text{A}$ | -- | 2.6 | 3.5 | V |
| | | $I_F=30\text{A}$, $T_J=125^\circ\text{C}$ | -- | 2.0 | -- | V |
| t_{rr} | Reverse Recovery Time | $I_F=1\text{A}$, $V_R=30\text{V}$, $di_F/dt=-200\text{A}/\mu\text{s}$ | -- | 27 | -- | ns |
| t_{rr} | Reverse Recovery Time | $V_R=600\text{V}$, $I_F=30\text{A}$ $di_F/dt=-200\text{A}/\mu\text{s}$, $T_J=25^\circ\text{C}$ | -- | 55 | -- | ns |
| I_{RRM} | Max. Reverse Recovery Current | | -- | 3.5 | -- | A |
| t_{rr} | Reverse Recovery Time | $V_R=600\text{V}$, $I_F=30\text{A}$ $di_F/dt=-200\text{A}/\mu\text{s}$, $T_J=125^\circ\text{C}$ | -- | 290 | -- | ns |
| I_{RRM} | Max. Reverse Recovery Current | | -- | 8.5 | -- | A |

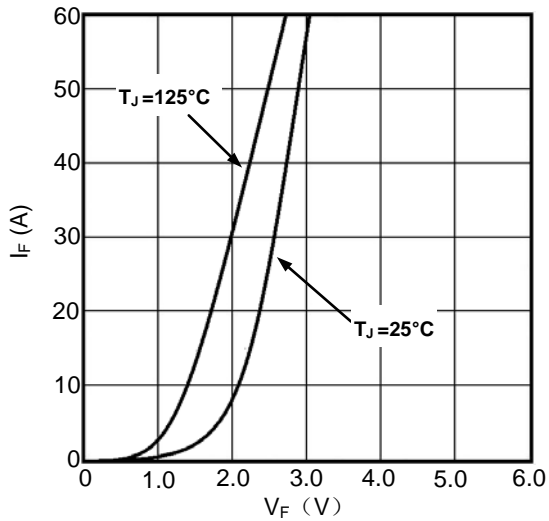

Fig1. Forward Voltage Drop vs Forward Current

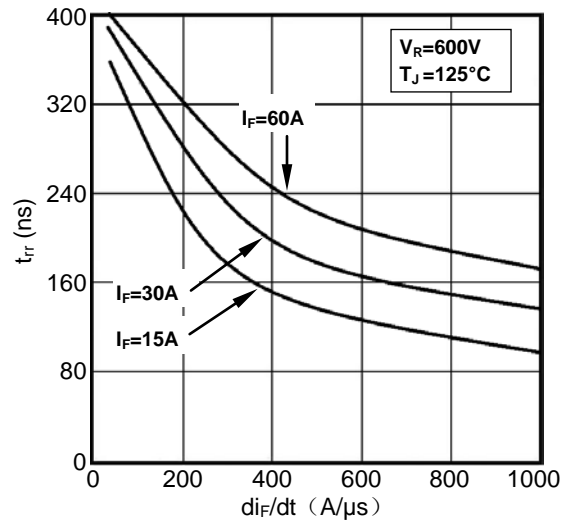

Fig2. Reverse Recovery Time vs di_F/dt

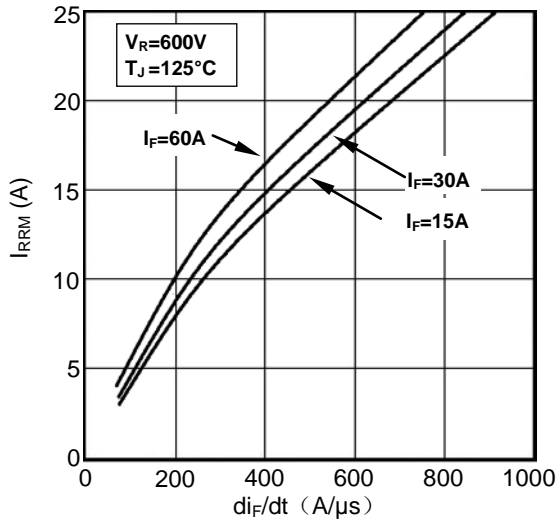

Fig3. Reverse Recovery Current vs di_F/dt

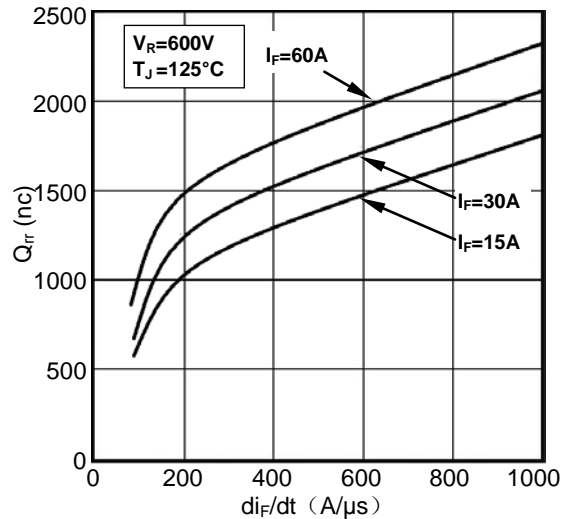

Fig4. Reverse Recovery Charge vs di_F/dt

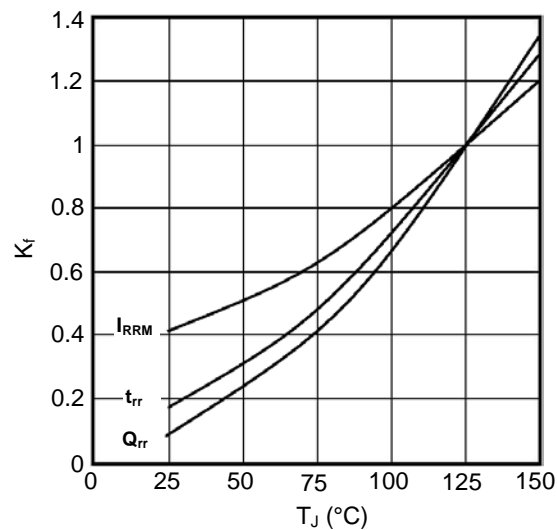

Fig5. Dynamic Parameters vs Junction Temperature

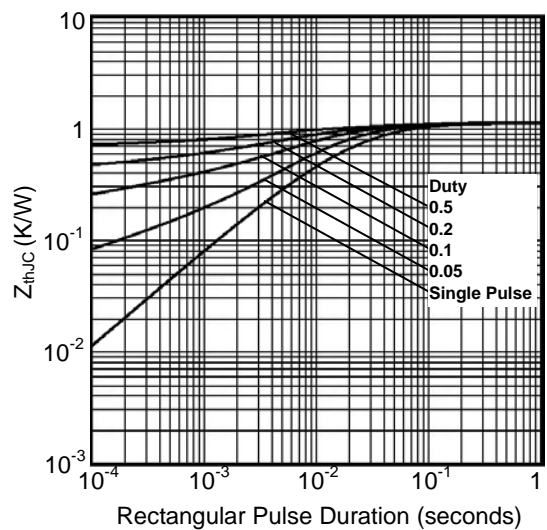

Fig6. Transient Thermal Impedance

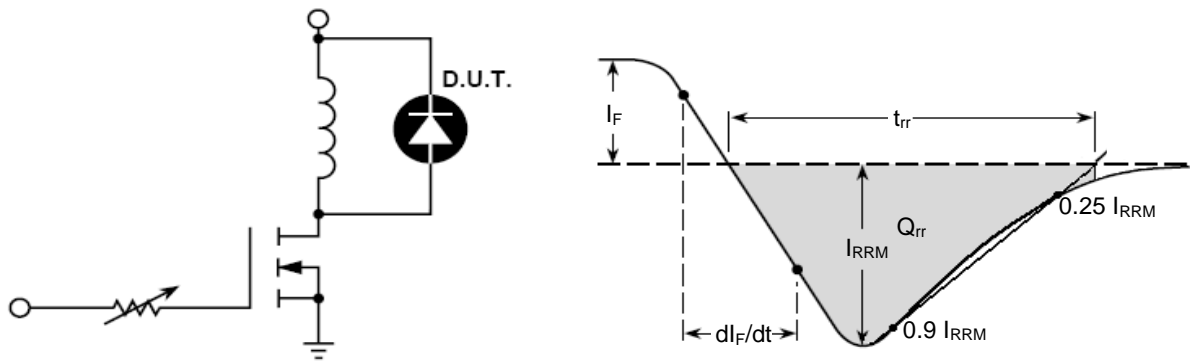
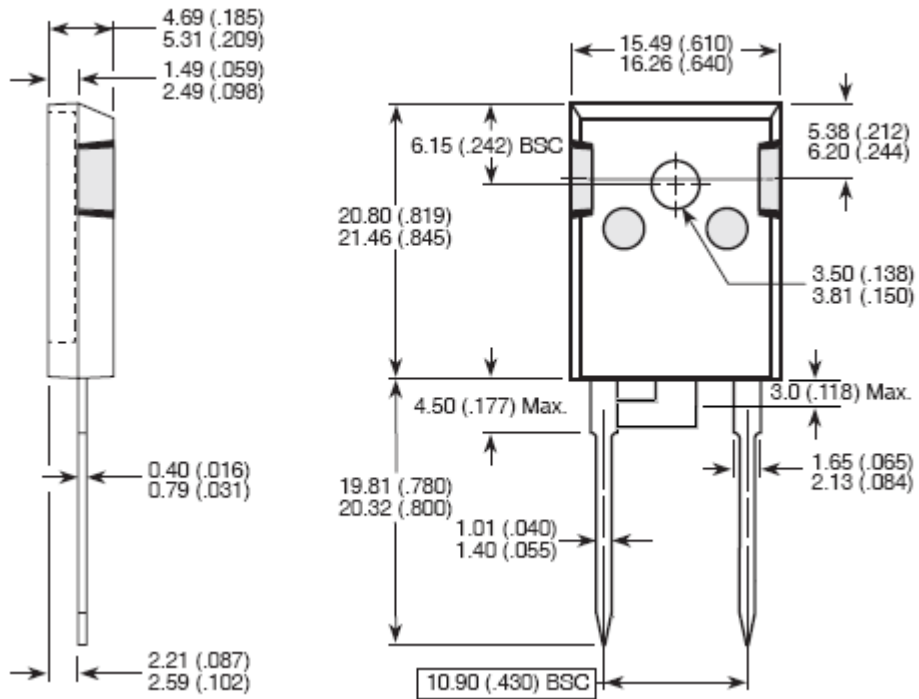

Fig7. Diode Reverse Recovery Test Circuit and Waveform



Dimensions in Millimeters and (Inchs)

Fig8. Package Outline