

BR25005L THRU BR2510L

SINGLE PHASE 25 AMP BRIDGE RECTIFIERS

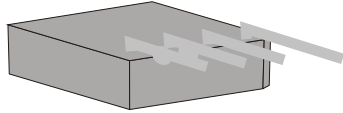
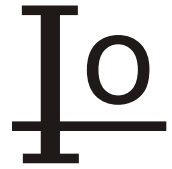

FEATURES

- * Superior thermal design
- * 400 amperes surge capability
- * Mounting: Hole thru for #8 screw
- * 1/4" universal faston terminal
- * Lead Free Finish/RoHS Compliant

VOLTAGE RANGE

50 to 1000 Volts

CURRENT

25.0 Ampere

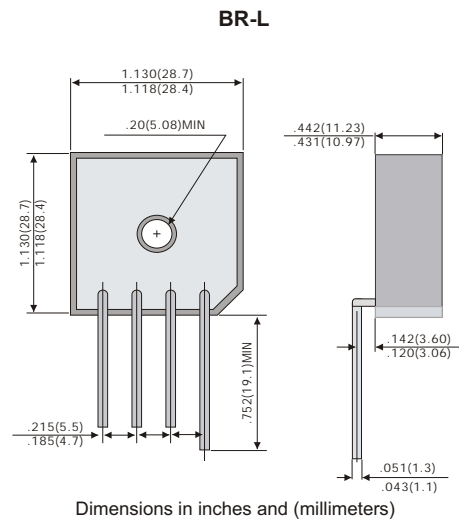

MAXIMUM RATINGS AND ELECTRICAL CHARACTERISTICS

Rating 25°C ambient temperature unless otherwise specified.
 Single phase half wave, 60Hz, resistive or inductive load.
 For capacitive load, derate current by 20%.

TYPE NUMBER	BR25005L	BR2501L	BR2502L	BR2504L	BR2506L	BR2508L	BR2510L	UNITS	
Maximum Recurrent Peak Reverse Voltage	50	100	200	400	600	800	1000	V	
Maximum RMS Voltage	35	70	140	280	420	560	700	V	
Maximum DC Blocking Voltage	50	100	200	400	600	800	1000	V	
Maximum Average Forward Rectified Current .375"(9.5mm) Lead Length at T _c =55°C								25	A
Peak Forward Surge Current, 8.3 ms single half sine-wave superimposed on rated load (JEDEC method)								400	A
Maximum Forward Voltage Drop per Bridge Element at 12.5A D.C.								1.1	V
Maximum DC Reverse Current at Rated DC Blocking Voltage								10	uA
								500	uA
Operating Temperature Range, T _j								-40 — +125	°C
Storage Temperature Range, TSTG								-40 — +125	°C

RATING AND CHARACTERISTIC CURVES (BR25005L THRU BR2510L)

FIG.1-TYPICAL FORWARD CURRENT DERATING CURVE

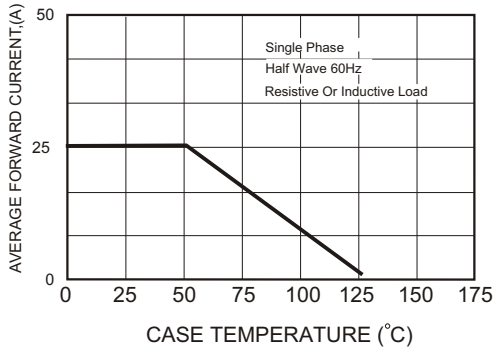

FIG.2-MAXIMUM NON-REPETITIVE FORWARD SURGE CURRENT

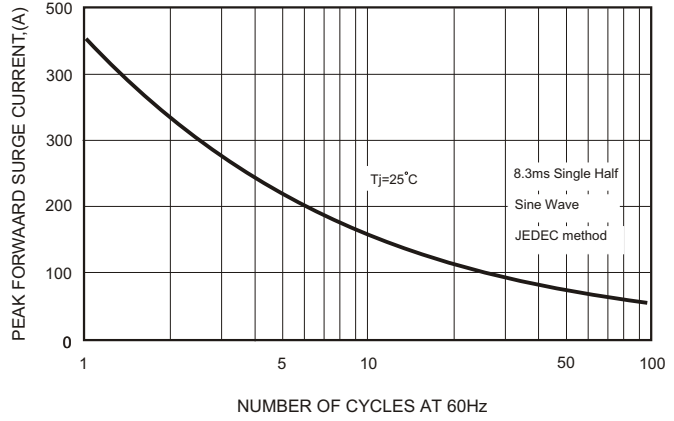

FIG.3-TYPICAL FORWARD CHARACTERISTICS

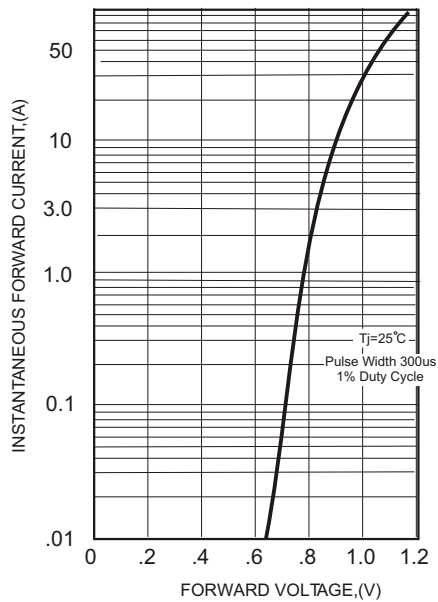

FIG.4-TYPICAL REVERSE CHARACTERISTICS

