



CHENMKO ENTERPRISE CO.,LTD

SURFACE MOUNT

P-Channel Enhancement Mode Field Effect Transistor

VOLTAGE 50 Volts CURRENT 0.13 Ampere

CHT84WGP

Halogens free devices

APPLICATION

- * Servo motor control.
- * Power MOSFET gate drivers.
- * Other switching applications.

FEATURE

- * Small surface mounting type. (SC-70/SOT-323)
- * High density cell design for low $R_{DS(ON)}$.
- * Suitable for high packing density.
- * Rugged and reliable.
- * High saturation current capability.
- * Voltage controlled small signal switch.

CONSTRUCTION

- * P-Channel Enhancement

MARKING

- * AW

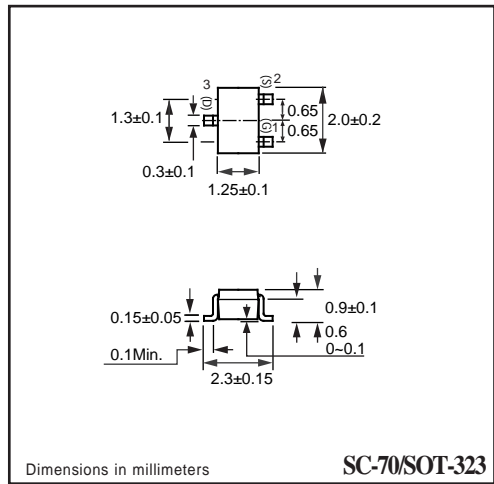
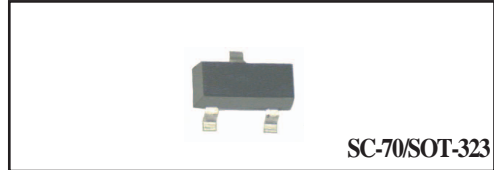

CIRCUIT

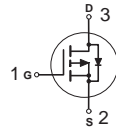

Absolute Maximum Ratings $T_A = 25^\circ\text{C}$ unless otherwise noted

Symbol	Parameter	CHT84WGP	Units
V_{DSS}	Drain-Source Voltage	-50	V
V_{GSS}	Gate-Source Voltage - Continuous	± 20	V
I_D	Maximum Drain Current - Continuous	-0.13	A
P_D	Maximum Power Dissipation	200	mW
T_J, T_{STG}	Operating and Storage Temperature Range	-55 to 150	$^\circ\text{C}$

Thermal characteristics

$R_{\theta JA}$	Thermal Resistance, Junction-to-Ambient	625	$^\circ\text{C/W}$
-----------------	---	-----	--------------------

RATING CHARACTERISTIC CURVES (CHT84WGP)

Electrical Characteristics $T_A = 25^\circ\text{C}$ unless otherwise noted

Symbol	Parameter	Conditions	Min	Typ	Max	Units
--------	-----------	------------	-----	-----	-----	-------

OFF CHARACTERISTICS

BV_{DSS}	Drain-Source Breakdown Voltage	$V_{GS} = 0\text{ V}, I_D = -250\ \mu\text{A}$	-50	-75		V
I_{DSS}	Zero Gate Voltage Drain Current	$V_{DS} = -50\text{ V}, V_{GS} = 0\text{ V}$			-15	μA
		$V_{DS} = -25\text{ V}, V_{GS} = 0\text{ V}$			-100	nA
I_{GSSF}	Gate - Body Leakage, Forward	$V_{GS} = 20\text{ V}, V_{DS} = 0\text{ V}$			10	nA
I_{GSSR}	Gate - Body Leakage, Reverse	$V_{GS} = -20\text{ V}, V_{DS} = 0\text{ V}$			-10	nA

ON CHARACTERISTICS (Note 1)

$V_{GS(th)}$	Gate Threshold Voltage	$V_{DS} = V_{GS}, I_D = 1.0\text{ mA}$	-0.8	-1.6	-2.0	V
$R_{DS(ON)}$	Static Drain-Source On-Resistance	$V_{GS} = -5.0\text{ V}, I_D = 0.1\text{ A}$		6	10	Ω
g_{FS}	Forward Transconductance	$V_{DS} = -25\text{ V}, I_D = 100\text{ mA}$	0.05			S

DYNAMIC CHARACTERISTICS

C_{iss}	Input Capacitance	$V_{DS} = -25\text{ V}, V_{GS} = 0\text{ V},$ $f = 1.0\text{ MHz}$			45	μF
C_{oss}	Output Capacitance				25	
C_{rss}	Reverse Transfer Capacitance				12	
t_{on}	Turn-On Time	$V_{DD} = -30\text{ V}$ $I_D = -270\text{ mA}, V_{GS} = -10\text{ V},$ $R_{GEN} = 50\ \Omega$		10		nS
t_{off}	Turn-Off Time			18		

RATING CHARACTERISTIC CURVES (CHT84WGP)

Typical Electrical Characteristics

Figure 1. On-Region Characteristics

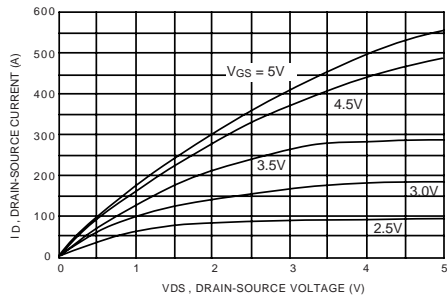

Figure 2. On-Resistance Variation with Temperature

