



CHENMKO ENTERPRISE CO.,LTD

Halogens free devices

SURFACE MOUNT

SCHOTTKY BARRIER RECTIFIER

VOLTAGE 40 Volts CURRENT 350 mAmpere

CH340SDWGP

APPLICATION

* Ultra high speed switching

FEATURE

- * Small surface mounting type. (SC-74/SOT-457)
- * High speed. (TRR=10nSec Typ.)
- * Suitable for high packing density.
- * Maximum total power dissipation is 225mW.

CONSTRUCTION

* Silicon epitaxial planar

MARKING

* DM1



SC-74/SOT-457

CIRCUIT

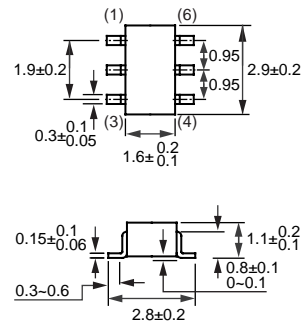
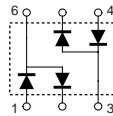

Dimensions in millimeters

SC-74/SOT-457

MAXIMUM RATINGS (At TA = 25°C unless otherwise noted)

RATINGS	SYMBOL	CH340SDWGP	UNITS
Maximum Non-Repetitive Peak Reverse Voltage	VRM	40	Volts
Maximum RMS Voltage	VRMS	28	Volts
Maximum Repetitive Peak Reverse and DC Blocking Voltage	VRRM, VDC	40	Volts
Forward Continuous Current	IFM	350	mAmps
Non-Repetitive Peak Forward Surge Current at 1.0Sec	IFSM	1.5	Amps
Typical Junction Capacitance between Terminal (Note 1)	CJ	50	pF
Maximum Reverse Recovery Time (Note 2)	TRR	10	nSec
Thermal Resistance Junction to Ambient (Note 3)	RθJA	444	°C/W
Maximum Operating and Storage Temperature Range	TJ, TSTG	-65 to +125	°C

ELECTRICAL CHARACTERISTICS (At TA = 25°C unless otherwise noted)

CHARACTERISTICS	SYMBOL	CH340SDWGP	UNITS
Maximum Instantaneous Forward Voltage @IF=20mA @IF=100mA @IF=200mA	VF	370 500 600	mVolts
Maximum Average Reverse Current @VR=30V	IR	5.0	uAmps

- NOTES : 1. Measured at 1.0 MHz and applied reverse voltage of 0 volts.
 2. Measured at applied forward current of 200mA and reverse current of 200mA.
 3. Device mounted on FR-4 by 1 inch X 0.85 inch X 0.062 inch
 4. ESD sensitive product handling required.

RATING CHARACTERISTIC CURVES (CH340SDWGP)

FIG. 1 - TYPICAL POWER DERATING CURVE

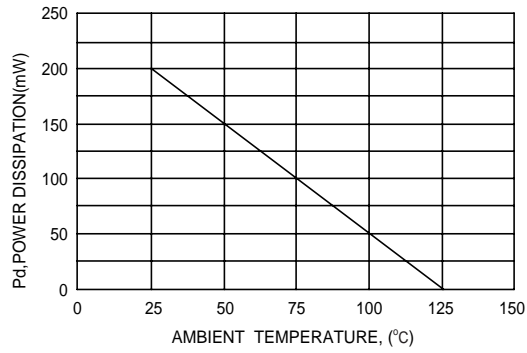

FIG. 2 - FORWARD CHARACTERISTICS

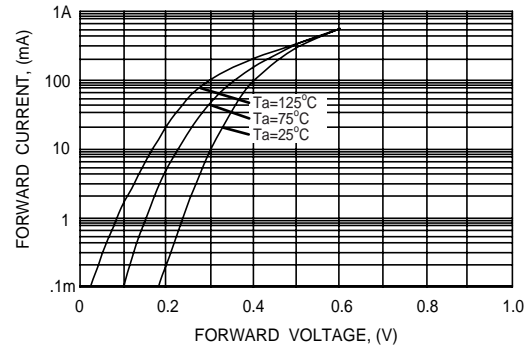

FIG. 3 - REVERSE CHARACTERISTICS

