



CHENMKO ENTERPRISE CO.,LTD

Halogens free devices

SURFACE MOUNT GLASS PASSIVATED FAST RECOVERY SILICON RECTIFIER

VOLTAGE RANGE 50 - 1000 Volts CURRENT 1.0 Ampere

**FSM11GP
THRU
FSM17GP**

FEATURES

- * Low leakage current
- * Ideal for surface mounted applications
- * Metallurgically bonded construction
- * Fast recovery times for high efficiency
- * Plastic package has Underwriters Laboratory Flammability Classification 94V-0
- * Glass passivated junction
- * High temperature soldering guaranteed : 260°C/10 seconds at terminals

MECHANICAL DATA

Case: JEDEC SMA molded plastic
Terminals: Solder plated, solderable per MIL-STD-750, Method 2026
Polarity: Indicated by cathode band
Weight: 0.002 ounces, 0.064 gram

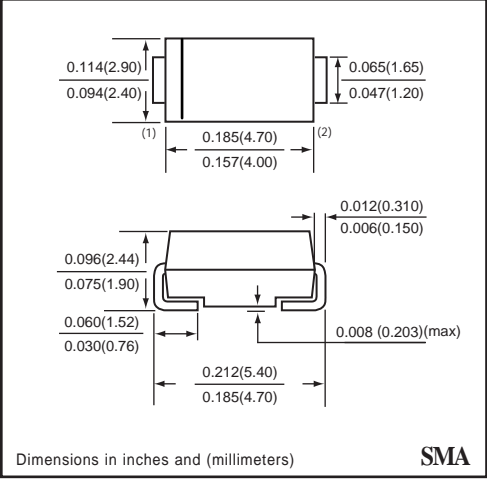

MAXIMUM RATINGS AND ELECTRICAL CHARACTERISTICS

Ratings at 25°C ambient temperature unless otherwise specified.
 Single phase, half wave, 60 Hz, resistive or inductive load.
 For capacitive load, derate current by 20%.

MAXIMUM RATINGS (At TA = 25°C unless otherwise noted)

RATINGS		SYMBOL	FSM11GP	FSM12GP	FSM13GP	FSM14GP	FSM15GP	FSM16GP	FSM17GP	UNITS
Maximum Recurrent Peak Reverse Voltage		VRRM	50	100	200	400	600	800	1000	Volts
Maximum RMS Voltage		VRMS	35	70	140	280	420	560	700	Volts
Maximum DC Blocking Voltage		Vdc	50	100	200	400	600	800	1000	Volts
Maximum Average Forward Rectified Current TL = 110°C		Io	1.0							Amps
Peak Forward Surge Current 8.3 ms single half sine-wave superimposed on rated load (JEDEC method)		IFSM	30							Amps
Typical Junction Capacitance (Note 1)		CJ	15							pF
Maximum Thermal Resistance	(Note 2)	R θJL	30							°C / W
	(Note 3)	R θJA	75							°C / W
Operating and Storage Temperature Range		TJ, TSTG	-65 to +150							°C

ELECTRICAL CHARACTERISTICS (At TA = 25°C unless otherwise noted)

CHARACTERISTICS	SYMBOL	FSM11GP	FSM12GP	FSM13GP	FSM14GP	FSM15GP	FSM16GP	FSM17GP	UNITS	
Maximum Instantaneous Forward Voltage at 1.0 A DC	VF	1.3								Volts
Maximum DC Reverse Current at Rated DC Blocking Voltage at TA = 25°C	IR	5.0								uAmps
Maximum Full Load Reverse Current Average, Full Cycle at TA = 55°C		100								uAmps
Maximum Reverse Recovery Time (Note 4)	trr	150				250		500		nSec

- NOTES :
1. Measured at 1.0 MHz and applied reverse voltage of 4.0 volts
 2. Thermal Resistance Junction to terminal 6.0 mm² copper pads to each terminal
 3. Thermal Resistance Junction to ambient 6.0 mm² copper pads to each terminal
 4. Test Conditions : IF = 0.5 A, IR = -1.0 A, IRR = -0.25 A

RATING CHARACTERISTIC CURVES (FSM11GP THRU FSM17GP)

FIG. 1 - TEST CIRCUIT DIAGRAM AND REVERSE RECOVERY TIME CHARACTERISTIC

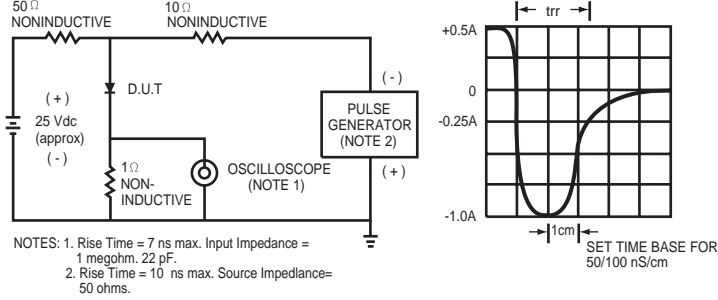

FIG. 2 - TYPICAL FORWARD CURRENT DERATING CURVE

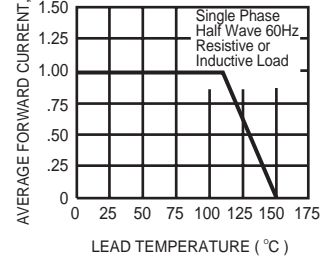

FIG. 3 - TYPICAL REVERSE CHARACTERISTICS

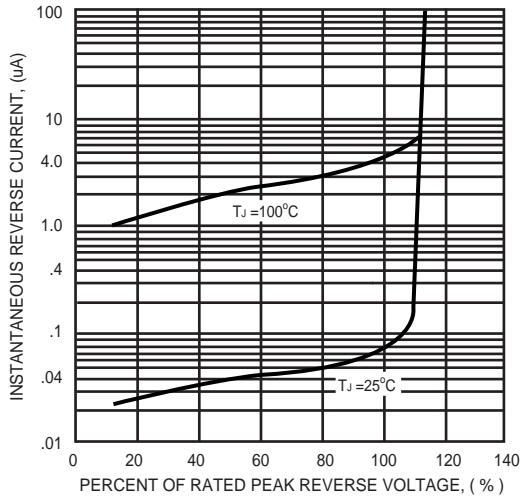

FIG. 4 - TYPICAL INSTANTANEOUS FORWARD CHARACTERISTICS

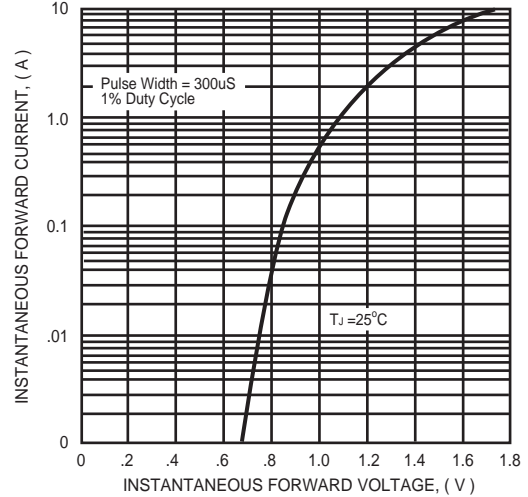

FIG. 5 - MAXIMUM NON-REPETITIVE FORWARD SURGE CURRENT

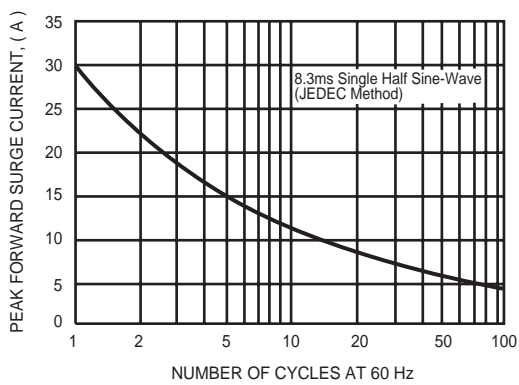

FIG. 6 - TYPICAL JUNCTION CAPACITANCE

